



SunModo PV Rack Mounting System

UL2703 Compliant

SMR Pitched Roof System



Please read carefully before installing

The SMR Product is tested and recognized to UL 2703 standards for safety grounding and bonding equipment and meets UL 1703 fire standards.

SunModo PV Rack Mount System can be used to mount photovoltaic (PV) panels in a wide variety of locations. All installations shall be in accordance with NEC requirements in the USA. The self-bonding system is for use with PV modules that have a maximum series fuse rating of 30A. Mechanical design loads per Mechanical design Loads per UL 2703: Downward Pressure: 16.7Psf(800Pa), Upward Pressure: 16.7Psf(800Pa), Down-Slope: 5Psf(239.4Pa)

Warning: In Canada the SMR Pitch Roof System can only be installed with maximum PV module area of 22.3 square feet (2.1 square meters).

Avertissement: Au Canada, le système de toiture en pente SMR ne peut être installé qu'avec une surface de module PV maximale de 22,3 pieds carrés (2,1 mètres carrés).

Table of Contents

| | |
|-----------------------------------------------|----|
| Installer Responsibility..... | 6 |
| Safety..... | 6 |
| SunModo Racking Self-Bonding System..... | 7 |
| SMR Roof Mount System Components..... | 8 |
| List of Compliant PV Modules..... | 12 |
| Fault Current Path Diagram..... | 15 |
| Tools Required for Installation..... | 16 |
| Torque Values..... | 19 |
| Sealing Gasket Compression..... | 19 |
| SoloFlash Installation Instructions..... | 20 |
| Pilot Hole..... | 20 |
| Flashing Installation..... | 20 |
| Lag Screw Installation..... | 20 |
| L-Foot Adaptor Installation Instructions..... | 21 |
| L-Foot Adaptor..... | 21 |
| L-Foot Connection..... | 21 |
| Rail to L-Foot Connection..... | 21 |

| | |
|-----------------------------------------------------|----|
| NanoMount Installation Instructions | 22 |
| Nano Rafter Mount Sealant Application..... | 22 |
| Roof Attachment | 22 |
| Rail Attachment..... | 22 |
| Nano Deck Mount Sealant Application..... | 23 |
| Roof Attachment | 23 |
| Rail Attachment..... | 23 |
| Optional Nano Rafter Mount Sealant Application..... | 24 |
| Rafter Attachment | 24 |
| Rail Attachment..... | 24 |
| TopTile Installation Instructions | 25 |
| Tile Hole..... | 25 |
| Underlayment Foam Application | 25 |
| Stanchion Installation..... | 25 |
| TopTile “Correct” Installation | 26 |
| TopTile “Acceptable” Installation | 26 |
| TopTile “Incorrect” Installation..... | 26 |
| 1” Spacer Assembly | 26 |
| Deck Screw Installation..... | 27 |
| Stanchion Sealing..... | 27 |
| Flashing Installation..... | 27 |
| L-Foot Attachment..... | 28 |
| Rail Attachment..... | 28 |
| TopTile Rafter Mount | 29 |
| NanoBit Installation Instructions | 30 |
| NanoBit Sealant Application..... | 30 |
| Roof Attachment | 30 |
| Rail Attachment..... | 30 |
| MRB Mount Installation Instructions | 31 |

SMR Pitched Roof System



| | |
|----------------------------------------------------|----|
| MRB Mount Installation..... | 31 |
| MRB Mount Attachment..... | 31 |
| MRB Mount with L-Foot..... | 31 |
| Standing Seam Clamp Installation Instructions..... | 32 |
| SMR Rail to Clamp Installation..... | 32 |
| L-Foot Attachment..... | 32 |
| SMR Rail to L-Foot Attachment..... | 32 |
| SMR Rail-free Clamp Installation..... | 33 |
| SMR End Clamp Attachment..... | 33 |
| SMR Mid Clamp Attachment..... | 33 |
| Rail Splice Installation Instructions..... | 34 |
| SMR Splice..... | 34 |
| SMR Splice to First Rail..... | 34 |
| SMR Splice to Second Rail..... | 34 |
| Thermal Break Installation Instructions..... | 35 |
| SMR Splice..... | 35 |
| Gap Between Rails..... | 35 |
| Bonding..... | 35 |
| SMR Rail and Splice Use Cases..... | 36 |
| Module Configuration:..... | 37 |
| MLPE Installation..... | 38 |
| Minimum Panel Height..... | 38 |
| End Clamp Location..... | 38 |
| SMR End Clamp..... | 39 |
| SMR Mid Clamp..... | 39 |
| SMR Mid Clamp Attachment..... | 39 |
| SMR100 Bottom Clamp..... | 40 |
| SMR100 Bottom Clamp Attachment..... | 40 |
| Ground Wire Attachment..... | 41 |

SMR Pitched Roof System



Ground Lug Installation.....41

UL 2703 Label Placement41

Wire Management Clip Installation42

Rail End Cap Attachment42

Conduit Clamp.....42

| | | |
|--------------------------------------------------------------------------------------------------------------------------------------------------------------------------------------------------------|---------------------------------------------------------------|---------------------------------------------------------------------------------------|
| <p>SunModo Corporation: Vancouver, Washington www.SunModo.com Ph.: 360-844-0048 info@sunmodo.com</p> | <p>Document Number: D10210-V6.1 ©2025 – SunModo Corp.</p> |  |
|--------------------------------------------------------------------------------------------------------------------------------------------------------------------------------------------------------|---------------------------------------------------------------|---------------------------------------------------------------------------------------|

Installer Responsibility

Before ordering and installing materials, all system layout dimensions should be confirmed by field measurements. SunModo reserves the right to alter, without notice, any details, proposals, or plans. Any inquiries that you may have concerning installation of the PV system should be directed to your SunModo Sales representative. Consult SunModo Sales for any information not contained in this manual. This manual is intended to be used as a guide when installing SunModo's racking system. It is the responsibility of the installer to ensure the safe installation of this product as outline herein.

- Installer shall employ only SunModo products detailed herein. The use of non SunModo components can cancel the letters of UL compliance and product warranties.
- Installer is responsible for determining that the roof, its rafters, connections, and other structural components can sustain the array under all environmental loading conditions per the codes and standards; consult with a licensed professional engineer.
- Installer shall guarantee that screws have adequate pullout strength and shear capacities.
- Installer shall adhere to the torque values specified in this Instruction Manual.
- Installer is responsible to install solar panels over a fire-resistant roof covering rated for the application.
- Installer shall adhere to all relevant local or national building codes. If any details of these installation instructions conflict with code requirements, installer should consult with SunModo.
- Installer shall guarantee the safe placement of all electrical details of the PV array.
- Installer to follow all applicable safety requirements during installation.
- Installer shall ensure bare copper grounding wire does not contact aluminum and zinc-plated steel components to prevent risk of galvanic corrosion.
- Installer is responsible for and shall provide an appropriate method of direct-to-earth grounding according to the latest edition of the National Electrical Code, including NEC 250: Grounding and Bonding, NEC 690: Solar Photovoltaic Systems, and CSA C22.2, Safety Standard for Electrical Installations, Canadian Electrical Code, Part 1.
- Installer shall comply with all applicable local, state, and national building codes, including periodic re-inspection of the installation for loose components, loose fasteners, and any corrosion. If loose components, or loose fasteners are found during periodic inspection, re-tighten immediately. If corrosion is found, replace affected components immediately.

Safety

Review relevant OSHA and other safety standards before following these instructions. The installation of solar PV systems is a dangerous procedure and should be supervised by trained and experienced personnel. It is not possible for SunModo to be aware of all the possible job site situations that could cause an unsafe condition to exist. The installer of the roof system is responsible for reading these instructions and determining the safest way to install the roof system. These instructions are provided only as a guide to show a knowledgeable, trained erector the correct part placement one to another. If following any of the installation steps would endanger a worker, the erector should stop work and decide upon a corrective action. Provide all required and recommended safety equipment for crew members working on the roof.

SMR Pitched Roof System



SunModo Racking Self-Bonding System

SunModo's SMR system meets the stringent requirements of UL 2703 and CSA C22.2 No. 61730-2 which covers rack mounting systems, mounting grounding/bonding components, and clamping/retention devices for photovoltaic (PV) modules. The SMR system is intended for, but not limited to, PV module installations on residential roof tops, commercial buildings, and freestanding ground mount structures.

The SMR system components are designed in accordance with the National Electrical Code, ANSI/NFPA 70 and Model Building Codes. These code requirements cover rack mounting systems and clamping devices intended for use with PV module systems with a maximum system voltage of 1500V.

The SMR self-bonding system is for use with PV modules that have a maximum series fuse rating of 30A. This means the maximum number of PV modules in the SMR system is limited by the system voltage, so if a system has multiple inverters, the SunModo racking system can theoretically go on forever.

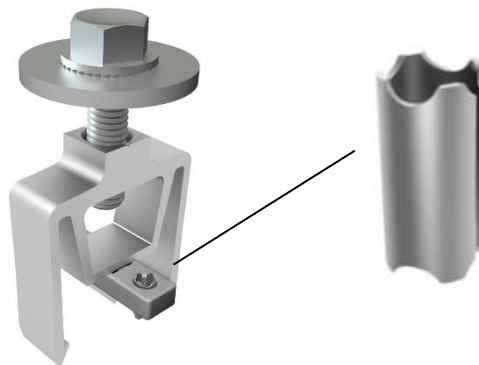

Mid Clamp with Bonding Pins

SMR Pitched Roof System



SMR Roof Mount System Components Primary Materials



SoloFlash includes:

- 9X12 Flashing
- 3" L-Foot
- 4" Lag Screw
- Seal Washer

SOLO-S

SOLO-B



NanoMount

NANOMOUNT-B



NanoBit

NANOBIT-B



Lag Bolt
with Sealing Washer

LAG-B



Deck Screw
#14 Self-tapping Screw with
Sealing Washer

SCREW-B



TopTile

TOPTILE-5-B

TOPTILE-7-B

TOPTILE-SPACE-S



MRB Mount

MRB-S



Standing Seam Clamp

SS-13-S

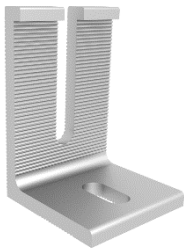

Open L-Foot

LFT-OPEN-3-S
LFT-OPEN-3-B
LFT-OPEN-4-S
LFT-OPEN-4-B

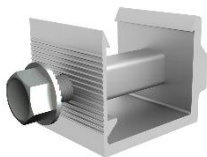

SMR100 L-Foot Adaptor

LFA-SMR100-S
LFA-SMR100-B



SMR Pop-On End Clamp

CLMP-END-SMR-S
CLMP-END-SMR-B



SMR Pop-On Mid Clamp

CLMP-MID-SMR-S
CLMP-MID-SMR-B
For single use only



SMR100 Bottom Clamp

CLMP-BOT-SMR100-S
CLMP-BOT-SMR100-B

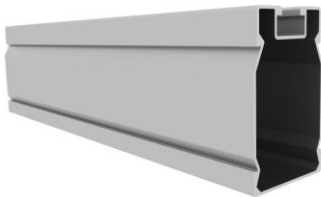

SMR100 Rail

SMR100-168-M
SMR100-168-M-US
SMR100-168-B



SMR100 Rail Splice

SPLC-SMR100



SMR100 Wire Management Clip

WIRE-SMR100-B

SMR Pitched Roof System



SMR100 Rail End Cap

CAP-SMR100-B

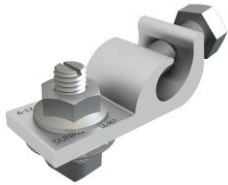

Grounding Lug

GRND-SMR
For single use only



MLPE Mount

MLPE-SMR

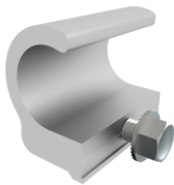

1" Conduit Clamp
3/4" Conduit Clamp

CLMP-CON-100-S
CLMP-CON-075-S

List of Compliant PV Modules

UL 2703 Qualified Modules for use with SunModo PV Racking Systems

| Evaluated PV Modules | |
|----------------------|------------------------------------------------------------------------------------------------------------------------------------------------------------------------------------------------------------------------------------------------------------------------------------------------------------------------------------------------------------------------------------------------------------------------------------------------------------------------------------------------------------------------------|
| Module manufacturer | Model numbers |
| Aptos | DNA-108-BF10-xxxW, DNA-108-MF10-xxxW, DNA-120-BF10-xxxW, DNA-120-MF10-xxxW, DNA-120-BF23-xxxW, DNA-120-MF23-xxxW, DNA-144-BF23-xxxW, DNA-144-MF23-xxxW, DNA-120-BF26-xxxW, DNA-120-MF26-xxxW, DNA-144-BF26-xxxW, DNA-144-MF26-xxxW |
| Astronergy | CHSM6612M-xxx, CHSM6612M/HV-xxx |
| AXITec Solar | AC-xxxP/60S, AC-xxxMH/120S, AC-xxxMH/120V, AC-xxxMH/144S, AC-xxxMH/144V |
| Boviet Solar | BVM6610M-xxx, BVM6612M-xxx, BVM6610P-xxx, BVM6612P-xxx |
| BlueSun Solar | BSMxxxM10-54HPH, BSMxxxM10-54NHB, BSMxxxM10-54NHS, BSMxxxPMB7-46SC, BSMxxxPMB6-60SC, BSMxxxPMB6-70SDC |
| C-Sun | CSUNxxx-60M, CSUNxxx-60P, CSUNxxx-72M, CSUNxxx-72P |
| Canadian Solar | CS3K-xxxMS, CS3N-xxxMS, CS3W-xxxMB-AG, CS3W-xxxP, CS3W-xxxPB-AG, CS6K-xxxM, CS6K-xxxMS, CS6P-xxxM, CS6R-xxxMS, CS6U-xxxP, CS6V-xxxM, CS6V-xxxP, CS6W-xxxMB, CS6X-xxxP |
| ET Solar | ET-P672xxxWW |
| Hansol | HSxxxSE-V01 |
| Hanwha Q Cells | Q.PEAK DUO-L-G4.2 xxxW, Q.PEAK DUO L-G5.2 xxxW, Q.PEAK DUO-G5-BLK xxxW, Q.PEAK DUO L-G6.2 xxxW, Q.PEAK DUO L-G7.3 xxxW, Q.PEAK DUO-G5 xxxW, Q.PRO L-G2 xxxW, Q.PEAK DUO ML-G10 xxxW, Q.PEAK DUO XL-G10 xxxW, Q.PEAK DUO XL-G11 xxxW, Q.PEAK DUO XR-G10 xxxW, Q.PEAK DUO BLK-G6 xxxW, Q.PEAK DUO L-G5.2 xxxW, Q.PEAK DUO L-G5.3 xxxW, Q.PEAK DUO L-G6.2 xxxW, Q.PEAK DUO BLK ML-G9 xxxW, Q.PEAK DUO BLK-G10 xxxW, Q.PEAK DUO BLK ML-G10 xxxW, Q.PEAK DUO BLK ML-G10+ xxxW, Q.PEAK DUO BLK-G10+/AC xxxW, Q.TRON BLK M-G2+ xxxW |
| Hareon | HR-xxxP-24/Ba |
| Heliene | 60M-320-G1-BLK, 66M-360-HJT-M2+BLK, 72M-xxx, 72M-BLK-xxx, 72P-xxx, 96M-xxx |
| Hyperion Solar | HY-DH108P8-xxxW-B, HY-DH144P8-xxxW |
| Hyundai | HiS-MxxxTI, HiS-SxxxTI, HiN-SxxxXG (BK), HiS-SxxxYH (BK), HiN-TxxxNF (BK) |
| Illuminate USA | IL5-72HBD-xxxM, IL8-66HGD-xxxM |
| Itek Energy | ITxxxHE, ITxxxSE |
| JA Solar | JAM60D00-xxx/BP, JAM66D45-xxx/LB, JAM72S09-xxx/PR, JAP6 72-xxx/3BB, JAM72D00-xxx/PR, JAM72S09 -xxx/PR |

SMR Pitched Roof System



| | |
|--------------------|---------------------------------------------------------------------------------------------------------------------------------------------------------------------------------------------------------------------------------------------------------------------------------------------------------------------------------------------------------------|
| Jinko | JKMxxx-60HL4, JKMxxx-60HL4-V, JKMxxx-72HL-V, JKMxxx-72HL4, JKMxxx-72HL4-V, JKMxxx-72L-V, JKMxxx-7RL3-TV, JKMxxxM-6RL3-B, JKMxxxM-60HBL, JKMxxxM-60HL, JKMxxxM-60L, JKMxxxM-72HL-TV, JKMxxxM-72HL-V, JKMxxxM-72HLM-TV, JKMxxxM-72HL4-BDVP, JKMxxxM-72HL4-TV, JKMxxxN-54HL4-B |
| Kyocera | KDxxxGX-LFB, KUxxx-6MCA, KDxxxGX-LFB2 |
| LG | LGxxxA1C-A6, LGxxxM1C-A6, LGxxxM1K-A6, LGxxxN1C-A6, LGxxxN1C-E6, LGxxxN1C-G4, LGxxxN1C-N5, LGxxxN1K-A6, LGxxxN1K-B6, LGxxxN1K-E6, LGxxxN1K-G4, LGxxxN1K-V5, LGxxxN1T-G4, LGxxxN2T-E6, LGxxxN2W-A5, LGxxxN2W-B3, LGxxxN2W-E6, LGxxxN2W-G4, LGxxxN3K-A6, LGxxxQAC-A6, LGxxxQAK-A6, LGxxxQ1C-A6, LGxxxQ1C-V5, LGxxxQ1K-A6, LGxxxQ1K-V5, LGxxxS1C-G4, LGxxxS2W-G4 |
| LONGi | IL5-72HBD-xxxM, IL8-66HGD-xxxM, LR4-60HPB-xxxM, LR4-72HPH-xxxM, LR5-54HABB G2-xxxM, LR5-54HABB V2-xxxM, LR5-54HABB 2.0+2.0-xxxM, LR5-72HBD-xxxM, LR5-72HBD Vx xxxM, LR5-54HPB-xxxM, LR5-54HTB-xxxW, LR6-60PE-BOW-xxxW, LR6-60HPH-BOB-xxxW, LR7-54HGBB-xxxW, LR672HPH-SOW-xxxW, LR7-54HGBB-xxxM, LR7-72HGD-xxxM, LR8-54HGBB-xxxM, LR8-66HGD-xxxM |
| Meyer Burger | MB_B120AyB_XXX, MB_TG120ByB_XXX, MB_W120AyB_XXX |
| Mission Solar | MSExxxSQ5T, MSExxxSQ8T, MSExxxSO9J, MSExxxSQ9S, MSExxxSR8T, MSExxxSR9S, MSExxxSX5T, MSExxxSX5R, MSExxxSX6Z, MSExxxSX6W |
| Mitrex | Mxxx-A1F, Mxxx-B1F, Mxxx-H1H, Mxxx-I1H, Mxxx-L3H |
| Mitsubishi | PV-MLExxxHD |
| Panasonic | EVPVxxxH, EVPVxxxK, EVPVxxxPK, VBHNxxxKA01, VBHNxxxKA03, VBHNxxxKJ01, VBHNxxxSA16, VBHNxxxSA17 |
| Philadelphia Solar | PS-M108(HCBF)-xxxW, PS-M144(HCBF)-xxxW, PS-MNB108(HCBF)xxxW, PS-MNB144(HCBF)xxxW, PS-MNB156(HCBF)xxxW |
| Phono Solar Tech | PSxxxM-20/U, PSxxxP-24T, PSxxxMI-24/TH, PSxxxMIH-24/TH, PSxxxMI-24/TH |
| REC Solar | RECxxxNP, RECxxxTP2, RECxxxTP2 BLK2, RECxxxTP2S 72, RECxxxTP2SM 72 RECxxxNP2 BLACK, RECxxxNP3 BLACK, RECxxxAA BLACK, RECxxxTP4 BLACK, RECxxxAA PURE, RECxxxAA PURE 2, RECxxxAA PURE-R, RECxxxTP5 |
| RECOM | RCM-xxx-SMS, RCM-xxx-SMD2, RCM-xxx-SMA, RCM-xxx-SMD2, RCM-xxx-6ME, RCM-xxx-6MF |
| Renesola | JC xxx M-24/Bbs, JC xxx M-24/Bb, JC xxx M-24/Abs, JC xxx S-24/Abs, JC xxx S-24/Bbs |
| Risen Solar | RSM40-8-xxxM, RSM120-8-xxxM, RSM144-6-xxxM, RSM150-8-xxxM, RSM156-6-xxxM |
| Sanyo | HIP-xxxBA3, HIT-NxxxA01 |
| SEG | SRP-xxx-6MA, SRP-xxx-6MA-DG, SRP-xxx-6MB, SRP-xxx-6MB-DG, SRP-xxx-6MB-HV, SRP-xxx-6PA, SRP-xxx-6PA-DG, SRP-xxx-6PA-HV, SRP-xxx-6PB, SRP-xxx-6PB-DG, SRP-xxx-6PB-HV, SEG-xxx-BMA, SEG-xxx-BMA-HV, SEG-xxx-BMB-HV, SEG-6MA-xxxBB, SEG-6MA-xxxBW, SEG-6MA-xxxWB, SEG-6MA-xxxWW, SEG-6MB-xxxBB, SEG-6MB-xxxBW, SEG-6MB-xxxWB, SEG-6MB-xxxWW, SEG-BMA-xxxBB, |

SMR Pitched Roof System



| | |
|----------------------------------|----------------------------------------------------------------------------------------------------------------------------------------------------------------------------------------------------------------------------------------------------------------------------------------------------------------------------------------------------------------------------------------------------------------------------------------------------------------------------------------------------------------------------------|
| | SEG-BMA-xxxBW, SEG-BMA-xxxBB, SEG-BMA-xxxWB, SEG-BMA-xxxWW, SRP-xxx-BMA, SRP-xxx-BMA-HV, SRP-xxx-BMB, SRP-xxx-BMB-HV, SRP-xxx-BMZ, SRP-xxx-BMZ-HV, SRP-xxx-BPA, SRP-xxx-BPA-HV, SEG-xxx-BMD-HV, SEG-480-BTB-BG, SEG-xxx-BTD-BG |
| Silfab | SLAxxxM, SLGxxxM, SLAxxxMCH, SLAxxxMWT, SLA-M xxx, SLA-X-xxx, SLG-X-xxx, SIL-xxx BK/BL/HC/HC+/HL/ML/NL/NT/NU/NX/QD/XM |
| Sirius | ELNSM54M-HC-xxx, ELNSM54M-HC-BF-xxx, ELNSM54M-HC-LV-xxx, ELNSM60M-HC-xxx, ELNSM60M-HC-BF-xxx, ELNSM60M-HC-LV-xxx, ELNSM66M-HC-xxx, ELNSM66M-HC-BF-xxx, ELNSM66M-HC-LV-xxx, ELNSM-xxx-72M-HC-BF |
| Solaria | PowerX-xxxR, PowerXT-xxxR-AC, PowerXT-xxxR-BX, PowerXT-xxxR-PX, PowerXT-xxxR-BD, PowerXT-xxxR-PD, PowerXT-xxxR-C-PD |
| Solar 4 America | S4Axxx-72MH5, S4Axxx-72MH5BB, S4Axxx-108MH10, S4Axxx-144MH10, S4A-USxxxB |
| SolarWorld | Sunmodule SW series: SW xxx mono and poly, SW xxx mono, SW xxx poly, Sunmodule Plus series: xxxW mono, Sunmodule Protect xxxW mono, Sunmodule SW xxx poly / Pro-Series, Sunmodule Pro-Series: xxxW poly, xxxW XL mono, Sunmodule Plus: xxxW mono |
| Stion | STO-xxxA |
| SunEdison | FxxxSMRD, FxxxSMRC, RxxxSMRC |
| SunPower Maxeon Technology | SPR-xxxE-WHT-D, SPR-Axxx, SPR-E19-xxx, SPR-E19-xxx-COM, SPR-E19-xxx, SPR-E20-xxx, SPR-E20-xxx, SPR-E20-xxx-COM, SPR-E20-xxx-D-AC, SPR-P17-xxx-COM, SPR-P5-xxx-UPP, SPR-X20-xxx-BLK, SPR-X20-xxx-BLK-B-AC, SPR-X20-xxx-C-AC, SPR-X21-xxx-BLK, SPR-X21-xxx-BLK-D-AC, SPR-X21-xxx, SPR-X21-xxx-COM, SPR-X21-xxx-D-AC, SPR-X21-xxx-BLK, SPR-X21-xxx-BLK-D-AC, SPR-X21-xxx-BLK, SPR-X21-xxx-COM, SPR-X22-xxx, SPR-X22-xxx-COM, SPR-X22-xxx-D-AC, SPR-X22-xxx-D-AC, SPR-MAX3-xxx-BLK-R, SPR-MAX6-xxx-BLK-E3-AC, SPR-MAX6-xxx-BLK-E4-AC |
| Trina | TSM-xxx PC/PA05, TSM-DEI5M(II), TSM-DEG15MC.20(II), TSM-DEI5H(II), TSM-DEG15HC.20(II), TSM-DEI5V(II), TSM-DEG15VC.20(II), TSM-DEG18MC.20(II) TSM-DEI9, TSM-DEG19C.20, TSM-DE21, TSM-DEG21C.20, TSM-NE09RC.05 |
| URE | FAMxxxE7G-BB, FAMxxxE8G-BB, FBMxxxMFG-BB, F6MxxxE7G-BB, FBMxxxMFG-BB |
| Yingli | YLxxxP-29b |
| ZnShine | ZXM6-NHLDD144 Series, ZXM6-NH120 Series, ZXM7-SHLDD144 Series, ZXM7-SH144 Series |

Fault Current Path Diagram

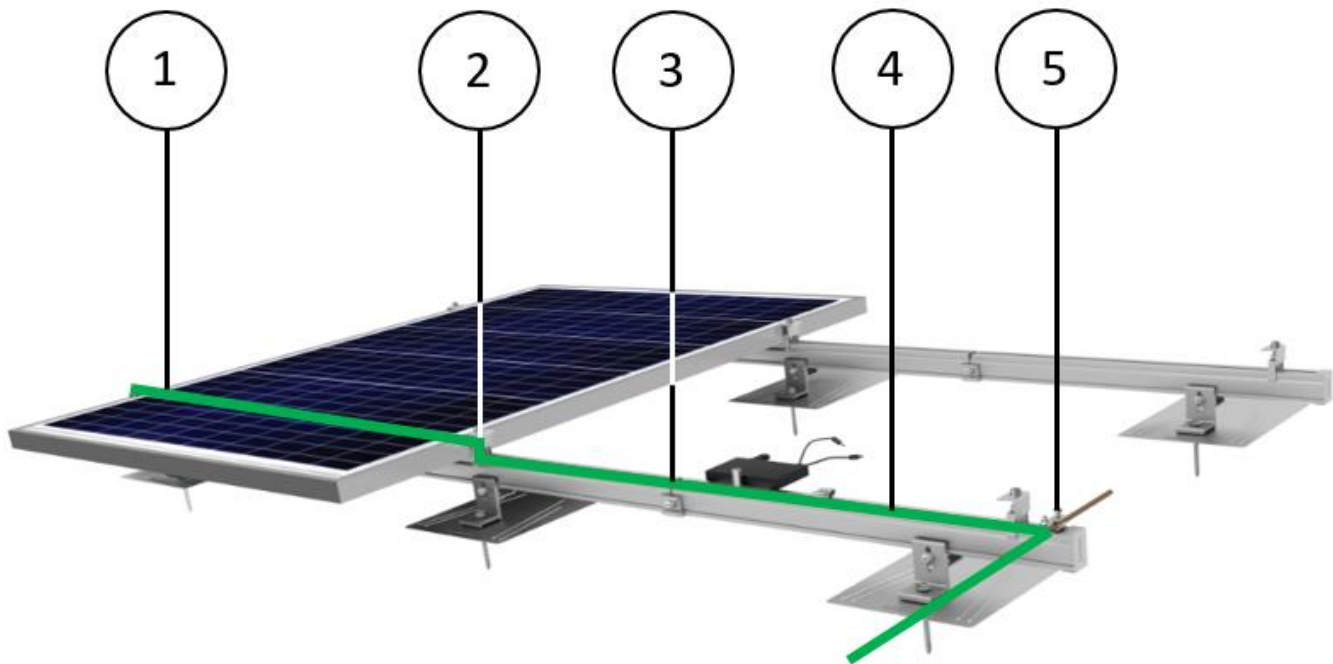

Items are listed in the fault current path in order from the PV Panel to the Grounding Lug:

1. PV Panel
2. Mid Clamp Kit
3. SMR Rail Splice
4. SMR Rail
5. Ground Lug

Fault Current Path 

SMR Pitched Roof System



Tools Required for Installation

Impact Driver



Band Saw



Adjustable Torque Wrench, 0 – 35 Nm



Tape measure



Chalk line or laser



Caulk gun and silicon sealant

- ChemLink M1 (or equivalent) for wood and composite roofs
- ChemLink DuraLink (or equivalent) for metal roofs



Shingle Ripper Pry Bar



Male hex drive impact socket adapter



SMR Pitched Roof System



13mm 6-point Socket



TopTile Installation only:
28mm (1-1/8") 6-point Socket



TopTile Installation only:
Drill



TopTile Installation only:
SHDIATool Diamond Core Drill Bits 1-1/2" or 2" for
Hard Stone Concrete Marble Granite Brick Laser
Welded Dry or Wet Hole Saws 50mm



TopTile Installation only:
SHDIATool Core Drill Bit Adapter 5/8"-11 Thread Male
to SDS Plus Shank



TopTile Installation only:
T25 Torx/Star Bit



Rafter Installation
An angle grinder can be used to cut a hole in the
tile. The hole should not exceed 2-1/2" x 3-1/2"



SMR Pitched Roof System



Rafter Installation

Use a stud finder to locate the roof rafter.
Walabot DiY 2 shown.



TopTile Installation only:

Dow Great Stuff FireBlock Polyurethane Spray Foam
(or equivalent)



TopTile Installation only:

POLYSET® RTA-1 Roof Tile Adhesive and Caulking

Please refer to the Florida Product Approval (FPA)
FL41592-R1 for sealant applications in Florida.



Anti-seize compound

(Permatex 80071 or equivalent)





Torque Values

These values must be adhered to both for mechanical strength and to insure the performance of the integral grounding and bonding features. It is required that a torque wrench be used to measure the bolt torque during final assembly, and it is recommended that anti-seize compound be applied to the screw threads.

| Hardware | Torque |
|-----------------------------------------|-------------------------------------------------|
| Ground Lug, Screw to secure Ground Wire | 5.6 Nm (4.2 ft.-lbs) |
| SMR End/Mid Clamps | 9.4 Nm to 10.2 Nm (6.9 ft-lbs to 7.5 ft-lbs) |
| SMR L-Foot Adaptor | 13 Nm to 15 Nm (10 ft-lbs to 11 ft-lbs) |
| Self-tapping Screws | As required |
| Lag Screw | As required |

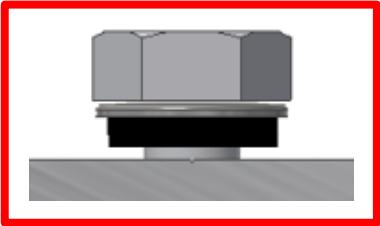
Sealing Gasket Compression

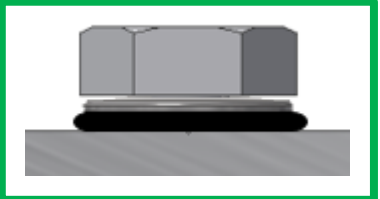
| | | |
|------------------------------------------------------------------------------------------------------------------------------------------------|-----------------------------------------------------------------------------------------------------------------------------------------------|----------------------------------------------------------------------------------------------------------------------------------------------|
| <p>Incorrect: Under compressed EPDM Sealing Gasket</p>  | <p>Incorrect: Over compressed EPDM Sealing Gasket</p>  | <p>Correct: Compression of EPDM Sealing Gasket</p>  |
|------------------------------------------------------------------------------------------------------------------------------------------------|-----------------------------------------------------------------------------------------------------------------------------------------------|----------------------------------------------------------------------------------------------------------------------------------------------|

SMR Pitched Roof System



SoloFlash Installation Instructions

Pilot Hole

From the desired rafter location, move down the roof 2-1/4" [57mm] from the bottom of the shingle, and drill the pilot hole for the Lag Bolt with a 7/32" [6mm] drill bit. For maximum strength, the hole should not be more than 3" in depth, and a drill stop may be used to insure this.

Clean sawdust, and fill hole with sealant, such as Chem-link M1 for wood and composite roofs.

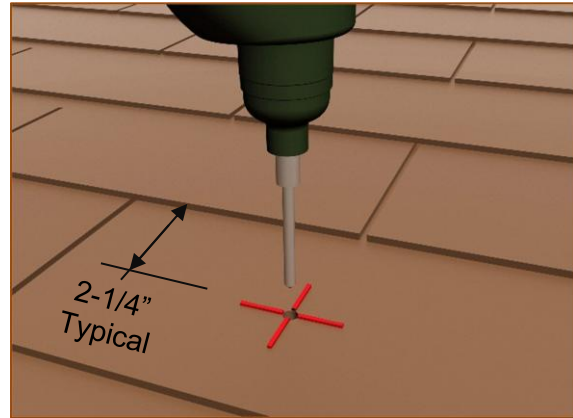

Flashing Installation

Use a roofing bar to lift the roof shingle, slide the flashing under the shingle.

Best practice tip:

For additional waterproofing apply beads of sealant as shown.

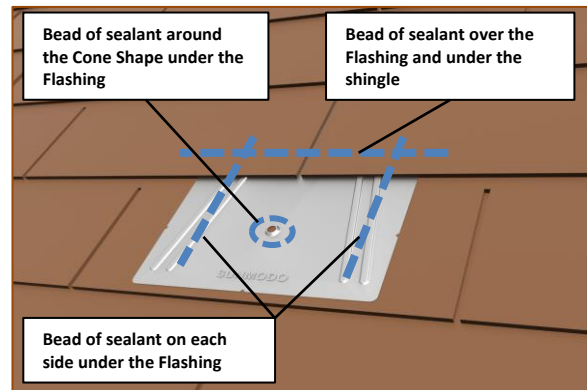

Lag Screw Installation

Place the L-Foot onto the Flashing and install the 5/16" [M8] Lag Screw using a 13mm hex socket.

Do not over tighten.

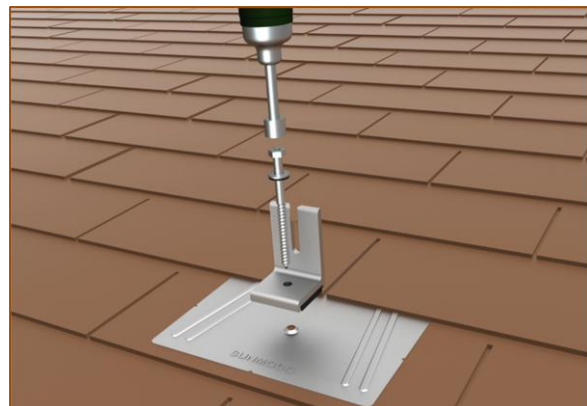

SMR Pitched Roof System



L-Foot Adaptor Installation Instructions

L-Foot Adaptor

Loosely install the L-Foot Adaptor to the L-Foot using the M8 Bolt provided.

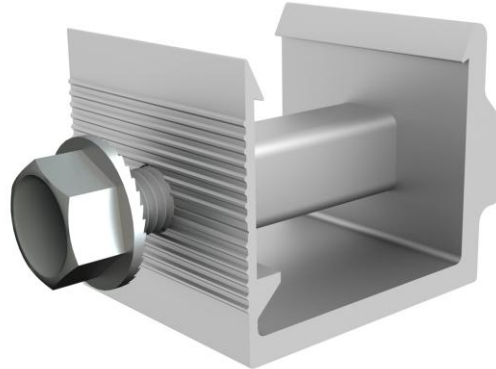

L-Foot Connection

Install the Rail onto the L-Foot and L-Foot Adaptor. Confirm that the hooks on the L-Foot Adaptor are fully engaged with the hooks on the side of the Rail.

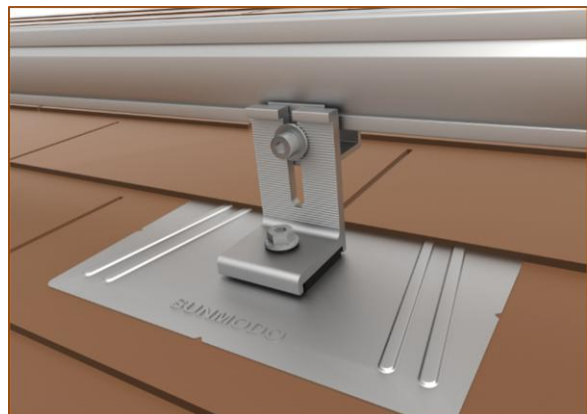

Rail to L-Foot Connection

Adjust the Rail to the desired height and then secure the Rail to the L-Foot Adaptor using the M8 Bolt; use a 13mm hex socket and torque to 13Nm (10 ft-lbs).

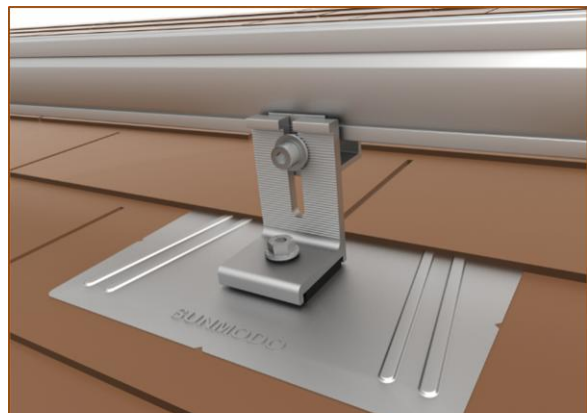

NanoMount Installation Instructions

Nano Rafter Mount Sealant Application

Apply a circular bead of composite roof sealant around the bottom of the NanoMount.

Apply additional sealant to the roof if needed to seal gaps between shingles or to smooth uneven surfaces.

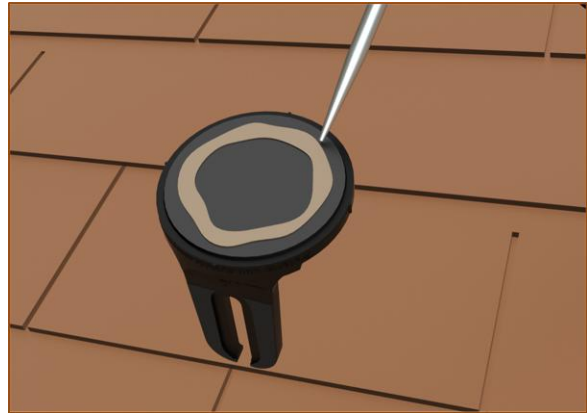

Roof Attachment

Locate the center of the rafter in the desired roof location and drill a 7/32" [6mm] pilot hole. Clean sawdust, and fill hole with sealant, such as Chem-link M1 for wood and composite roofs.

Use a 13mm hex socket to install the 5/16" [M8] Lag Screw.

Do not over tighten.



Rail Attachment

Loosely install the L-Foot Adaptor to the L-Foot using the M8 Bolt provided.

Install the Rail onto the L-Foot and L-Foot Adaptor. Confirm that the hooks on the L-Foot Adaptor are fully engaged with the hooks on the side of the Rail.

Adjust the Rail to the desired height and then secure the Rail to the L-Foot Adaptor using the M8 Bolt; use a 13mm hex socket and torque to 13Nm (10 ft-lbs).



Nano Deck Mount Sealant Application

Apply a circular bead of composite roof sealant around the bottom of the NanoMount.

Apply additional sealant to the roof if needed to seal gaps between shingles or to smooth uneven surfaces.

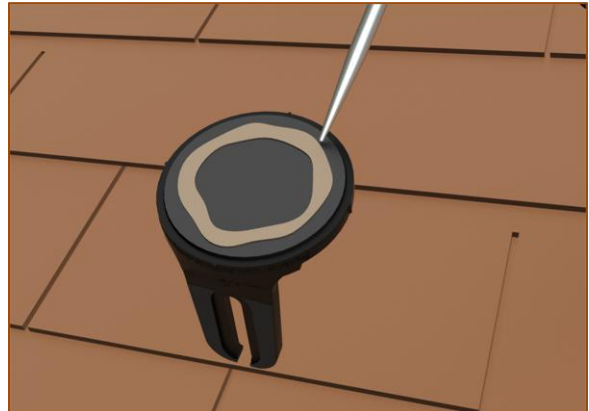

Roof Attachment

Locate the desired roof location and install the 4X Self-Tapping Screws with Sealing Washers.

Use a 13mm hex socket to install the Self-Tapping Wood Screws.

Do not over tighten.



Rail Attachment

Loosely install the L-Foot Adaptor to the L-Foot using the M8 Bolt provided.

Install the Rail onto the L-Foot and L-Foot Adaptor. Confirm that the hooks on the L-Foot Adaptor are fully engaged with the hooks on the side of the Rail.

Adjust the Rail to the desired height and then secure the Rail to the L-Foot Adaptor using the M8 Bolt; use a 13mm hex socket and torque to 13Nm (10 ft-lbs).



Optional Nano Rafter Mount Sealant Application

Apply a circular bead of composite roof sealant around the bottom of the NanoMount.

Apply additional sealant to the roof if needed to seal gaps between shingles or to smooth uneven surfaces.

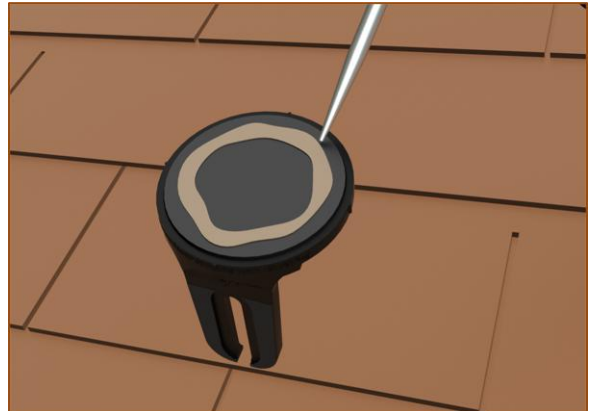

Rafter Attachment

Locate the desired rafter or joist location and install the 2X Self-Tapping Screws with Sealing Washers.

Use a 13mm hex socket to install the Self-Tapping Wood Screws into the rafter or joist.

Do not over tighten.



Rail Attachment

Loosely install the L-Foot Adaptor to the L-Foot using the M8 Bolt provided.

Install the Rail onto the L-Foot and L-Foot Adaptor. Confirm that the hooks on the L-Foot Adaptor are fully engaged with the hooks on the side of the Rail.

Adjust the Rail to the desired height and then secure the Rail to the L-Foot Adaptor using the M8 Bolt; use a 13mm hex socket and torque to 13Nm (10 ft-lbs).



TopTile Installation Instructions

Tile Hole

Locate the desired location of the TopTile Mount. Using a 2" tile hole saw, drill a hole into the tile.

Remove the tile dust from around the hole and the tile dust on the underlayment.

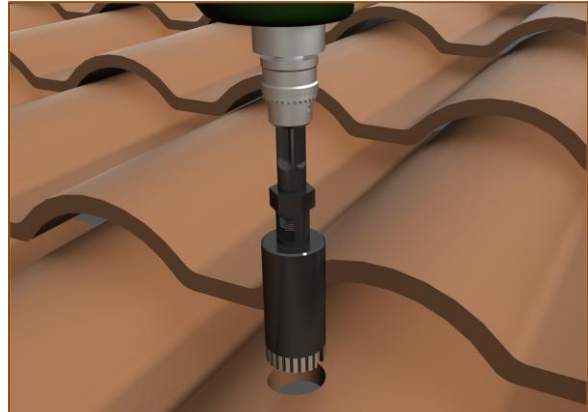

Underlayment Foam Application

After clearing away the tile dust on the underlayment, spray a 4" to 6" circular bead of polyurethane foam sealant onto the underlayment.

We recommend POLYSET® RTA-1 Roof Tile Adhesive, or Great Stuff FireBlock, or any polyurethane spray foam approved in your jurisdiction is acceptable.

Please refer to the Florida Product Approval (FPA) FL41592-R1 for sealant applications in Florida.



Stanchion Installation

Install the Stanchion using a 28mm Socket. Torque until the stanchion and gasket are fully seated.



SMR Pitched Roof System



TopTile "Correct" Installation

The 3 wood screw stanchion holes are above the tile and below the collar of the EPDM cover on the Flashing.

Note: Repositioning the stanchion higher or lower along the tile will increase or decrease the position of the 3 wood screw stanchion holes.

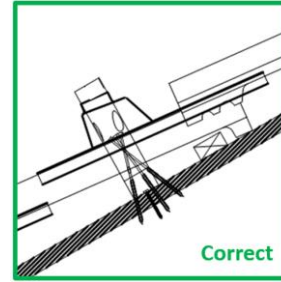

TopTile "Acceptable" Installation

The 3 wood screw stanchion holes are above the tile, and also above the collar of the EPDM cover on the Flashing. POLYSET® RTA-1 Roof Tile Adhesive spray foam can be used to prevent water infiltration.

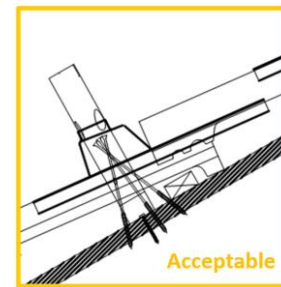

TopTile "Incorrect" Installation

The 3 wood screw stanchion holes are below the tile profile. In this position the wood screws cannot be installed.

In this situation we recommend adding a 1" Spacer to the stanchion.

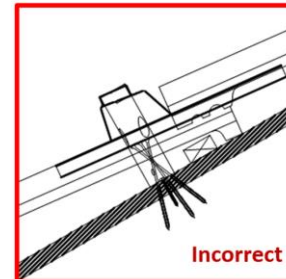

1" Spacer Assembly

If required add a 1" Spacer to the bottom of the stanchion. Remove the EPDM Washer, install the 1" Spacer, and replace the EPDM Washer with the rubber gasket facing down.



SMR Pitched Roof System

Deck Screw Installation

Install the 3 wood screws into the stanchion using a T25 Torx/Star Bit.

Due to the side driving force of installing the screws into the sides of the stanchion, care should be taken to keep the stanchion plumb.



Stanchion Sealing

Spray a circular bead of POLYSET® RTA-1 Roof Tile Adhesive around the hole and the Stanchion to create a watertight seal.



Flashing Installation

Remove the protective linear covering the butyl tape.

Install Flashing over Stanchion and onto the tile.



L-Foot Attachment

Install the L-Foot with its M8 Bolt onto the top of the Stanchion; use a 13mm hex socket and torque to 13Nm (10 ft-lbs).



Rail Attachment

Loosely install the L-Foot Adaptor to the L-Foot using the M8 Bolt provided.

Install the Rail onto the L-Foot and L-Foot Adaptor. Confirm that the hooks on the L-Foot Adaptor are fully engaged with the hooks on the side of the Rail.

Adjust the Rail to the desired height and then secure the Rail to the L-Foot Adaptor using the M8 Bolt; use a 13mm hex socket and torque to 13Nm (10 ft-lbs).



TopTile Rafter Mount

Step 1: Rafter Locations

Starting at the eave locate the roof rafters. Using a stud finder locate the rafter at the peak of the roof. With these two points established, snap a chalk line outlining the rafter locations on the tile.

Step 2: Cut the Tile

Select the desired location for the TopTile Stanchion. Use an angle grinder to cut a square, or rectangular hole into the tile. To achieve a good watertight seal, the rectangular hole should not exceed 2-1/2" x 3-1/2". Remove the tile dust from around the hole and the tile dust on the underlayment.

Step 3: Continue Installation

Continue installing the TopTile using the Deck Mount installation instructions.

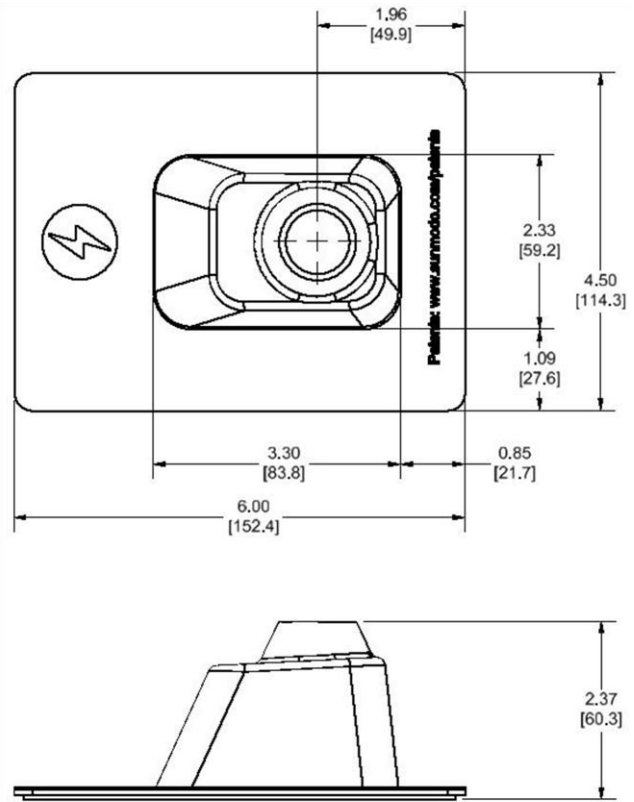

NanoBit Installation Instructions

NanoBit Sealant Application

To ensure a strong and watertight seal, wipe away excess dirt or debris from the mounting location.

Apply a circular bead of sealant around the bottom of the NanoBit.



Roof Attachment

Locate the center of the truss, rafter, or purlin in the desired roof location and drill a 7/32" [6mm] pilot hole. Clean sawdust, and fill hole with sealant, such as Chem-link M1.

Use a 13mm hex socket to install the 5/16" [M8] Lag Screw.

Do not over tighten.



Rail Attachment

Loosely install the L-Foot Adaptor to the L-Foot using the M8 Bolt provided.

Install the Rail onto the L-Foot and L-Foot Adaptor. Confirm that the hooks on the L-Foot Adaptor are fully engaged with the hooks on the side of the Rail.

Adjust the Rail to the desired height and then secure the Rail to the L-Foot Adaptor using the M8 Bolt; use a 13mm hex socket and torque to 13Nm (10 ft-lbs).



MRB Mount Installation Instructions

MRB Mount Installation

The MRB Mount installs into 26-gauge sheet metal, 1/2 plywood or 7/16 OSB roof decking material. Mount is designed to fit on the most popular R-Panel and U-Panel trapezoidal and corrugated types of metal roofs.

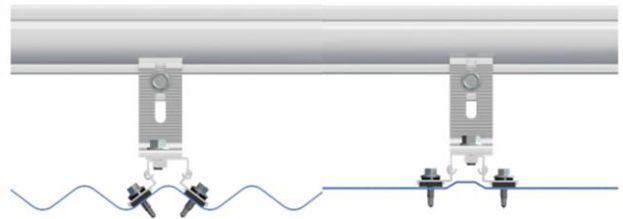

MRB Mount Attachment

Remove the protective linear covering the EPDM gasket adhesive.

Secure to 26-gauge minimum thickness sheet metal using four 1/4 x 1" Hex Washer Head Self-drilling Screws.

Adjust the L-Foot with its M8 Bolt onto the top of the clamp; use a 13mm hex socket and torque to 13Nm (10 ft-lbs).

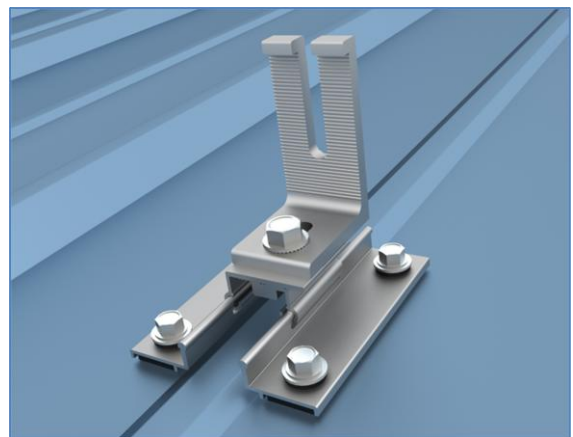

MRB Mount with L-Foot

Loosely install the L-Foot Adaptor to the L-Foot using the M8 Bolt provided.

Install the Rail onto the L-Foot and L-Foot Adaptor. Confirm that the hooks on the L-Foot Adaptor are fully engaged with the hooks on the side of the Rail.

Adjust the Rail to the desired height and then secure the Rail to the L-Foot Adaptor using the M8 Bolt; use a 13mm hex socket and torque to 13Nm (10 ft-lbs).



Standing Seam Clamp Installation Instructions

SMR Rail to Clamp Installation

Snap a line or use a laser to line up the clamps on the roof panel seams. Tighten to 4.5 ft. lbs. of torque for steel or aluminum roof panels.

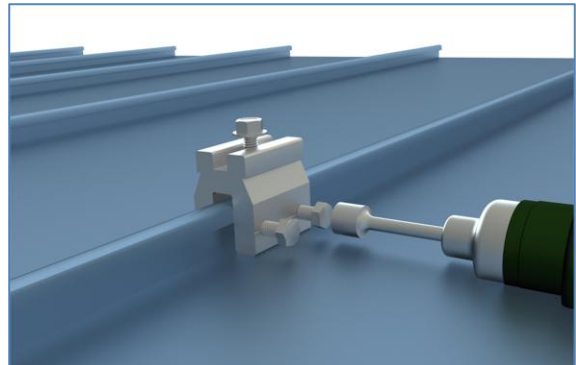

L-Foot Attachment

Install the L-Foot with using the M8 Bolt onto the top of the clamp; use a 13mm hex socket and torque to 13Nm (10 ft-lbs).

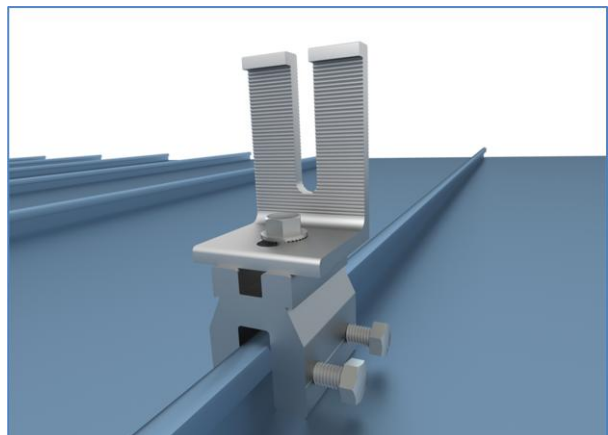

SMR Rail to L-Foot Attachment

Loosely install the L-Foot Adaptor to the L-Foot using the M8 Bolt provided.

Install the Rail onto the L-Foot and L-Foot Adaptor. Confirm that the hooks on the L-Foot Adaptor are fully engaged with the hooks on the side of the Rail.

Adjust the Rail to the desired height and then secure the Rail to the L-Foot Adaptor using the M8 Bolt; use a 13mm hex socket and torque to 13Nm (10 ft-lbs).

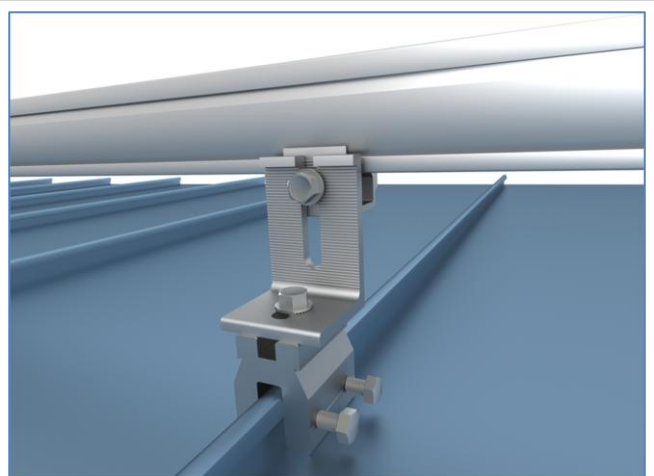

SMR Pitched Roof System

SMR Rail-free Clamp Installation

Snap a line or use a laser to line up the clamps on the roof panel seams. Tighten to 4.5 ft. lbs. of torque for steel or aluminum roof panels.

Remove the M8 Bolt locate on the top of the Clamp.

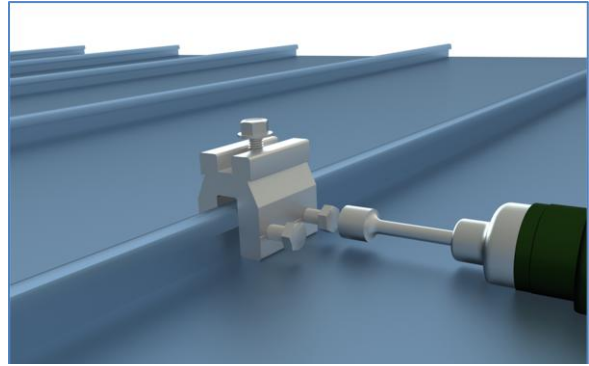

SMR End Clamp Attachment

Install the End Clamp on the Rail at the ends of the PV module array:

- Confirm that the hooks on the End Clamp are fully engaged with the hooks on the side of the Rail.
- Use your free hand to support the End Clamp against the panel frame while tightening.
- Use a 13mm hex socket and torque to 9.4 Nm (6.9 ft-lbs).

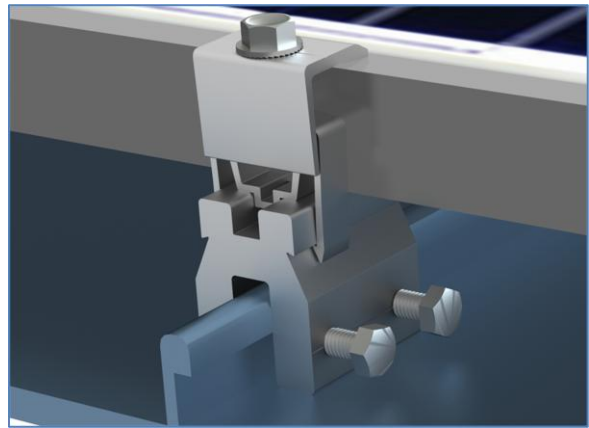

SMR Mid Clamp Attachment

Install the Mid Clamp on the Standing Seam Clamp between PV panels.

- Confirm that the hooks on the Mid Clamp are fully engaged with the hooks on the side of the Standing Seam Clamp.
- Secure the PV panel frame to the Standing Seam Clamp using the Mid Clamp; use a 13mm hex socket and torque to 9.4 Nm (6.9 ft-lbs).

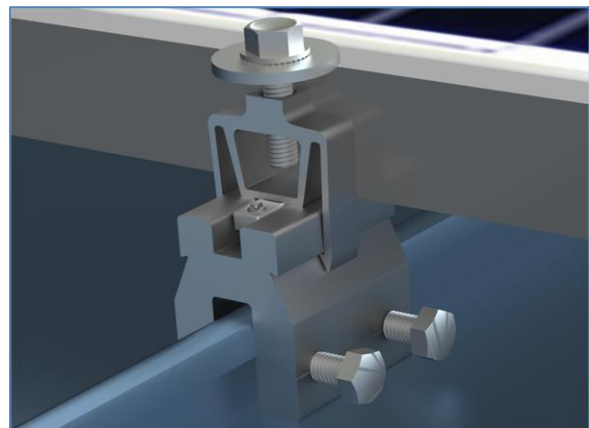

Rail Splice Installation Instructions

SMR Splice

The SMR Rail Splice has been designed to be both a structural and bonding rail splice.

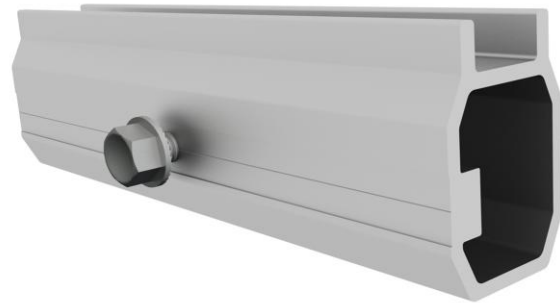

SMR Splice to First Rail

Insert the SMR Splice into the first Rail.

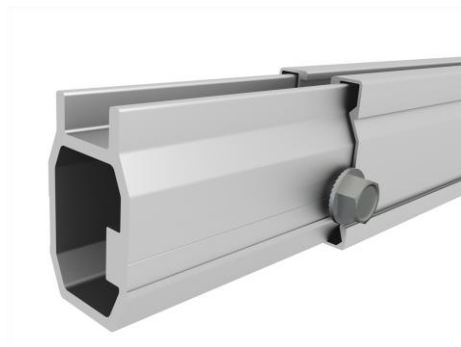

SMR Splice to Second Rail

Insert the SMR Splice into the second Rail until both Rails are stopped by the M8 Bolt.

Secure the SMR Rail Splice by tightening the M8 Bolt; use a 13mm hex socket and torque to 13Nm (10 ft-lbs).

See the SMR Rail and Splice Use Case section for permissible Splice locations.

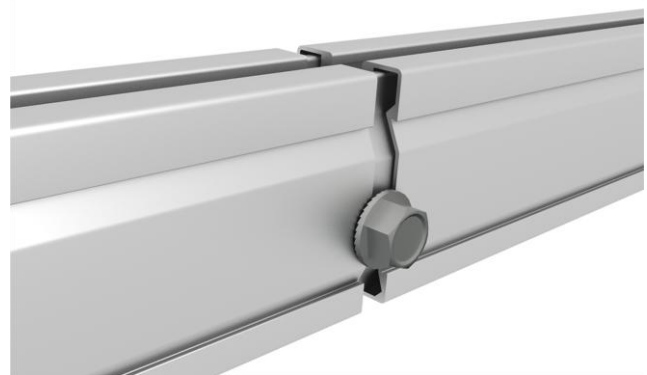

SMR Pitched Roof System



Thermal Break Installation Instructions

SMR Splice

The maximum permissible continuous Rail run before a thermal break is 60 feet.

In cases where a thermal break is necessary it is recommended to use an SMR Splice in conjunction with the Wiley Bonding Jumper (WEEBBNDJMP8.0) to insure continuous bonding across the thermal break.

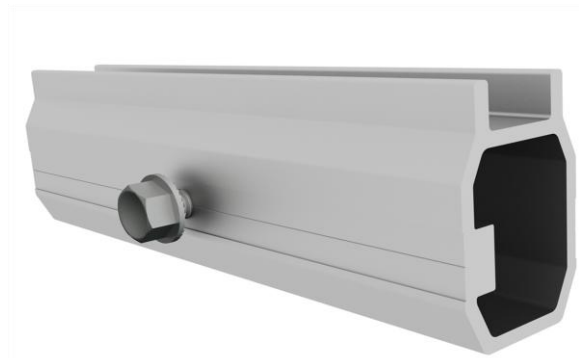

Gap Between Rails

Insert the SMR Splice into the Rails with a 1-1/4-inch gap between Rails.

Modules cannot be installed over a thermal break. The row of continuous modules must end before the thermal break and a new row must start after the thermal break.

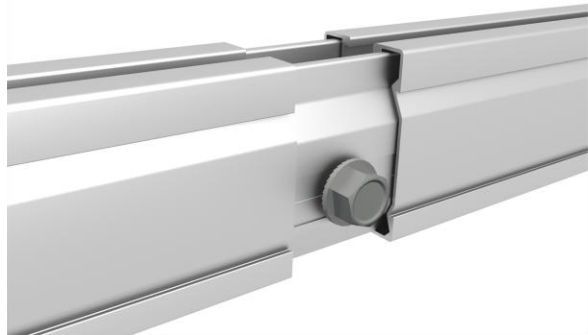

Bonding

Secure the Wiley Bonding Jumper to the Rails using either the SMR Microinverter Mounting Kit (shown) or by using M8 Nuts and Bolts.

Ensure a loop is left in the Bonding Jumper to allow for thermal expansion and torque to 13Nm (10 ft-lbs).

See the SMR Rail and Splice Use Case section for permissible Splice locations.

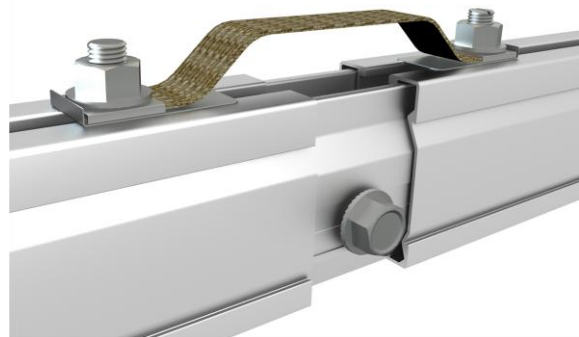

SMR Rail and Splice Use Cases

SMR span charts are available for download on the SunModo website.

Rail shall be continuous and not spliced over a minimum of 2 supports except for approved span lengths per SunModo’s span charts. In these cases, it is acceptable to use a minimum of 1 support per rail section as long as all supports are located at a minimum of 48-inches on center and the first and last rail sections have a minimum of 2 supports.

Installation over roof overhangs or within 10” of any roof edge is not recommended.

Maximum end cantilever of aluminum support rail shall not exceed 1/3 of allowable span in the roof wind pressure zone of the cantilever.

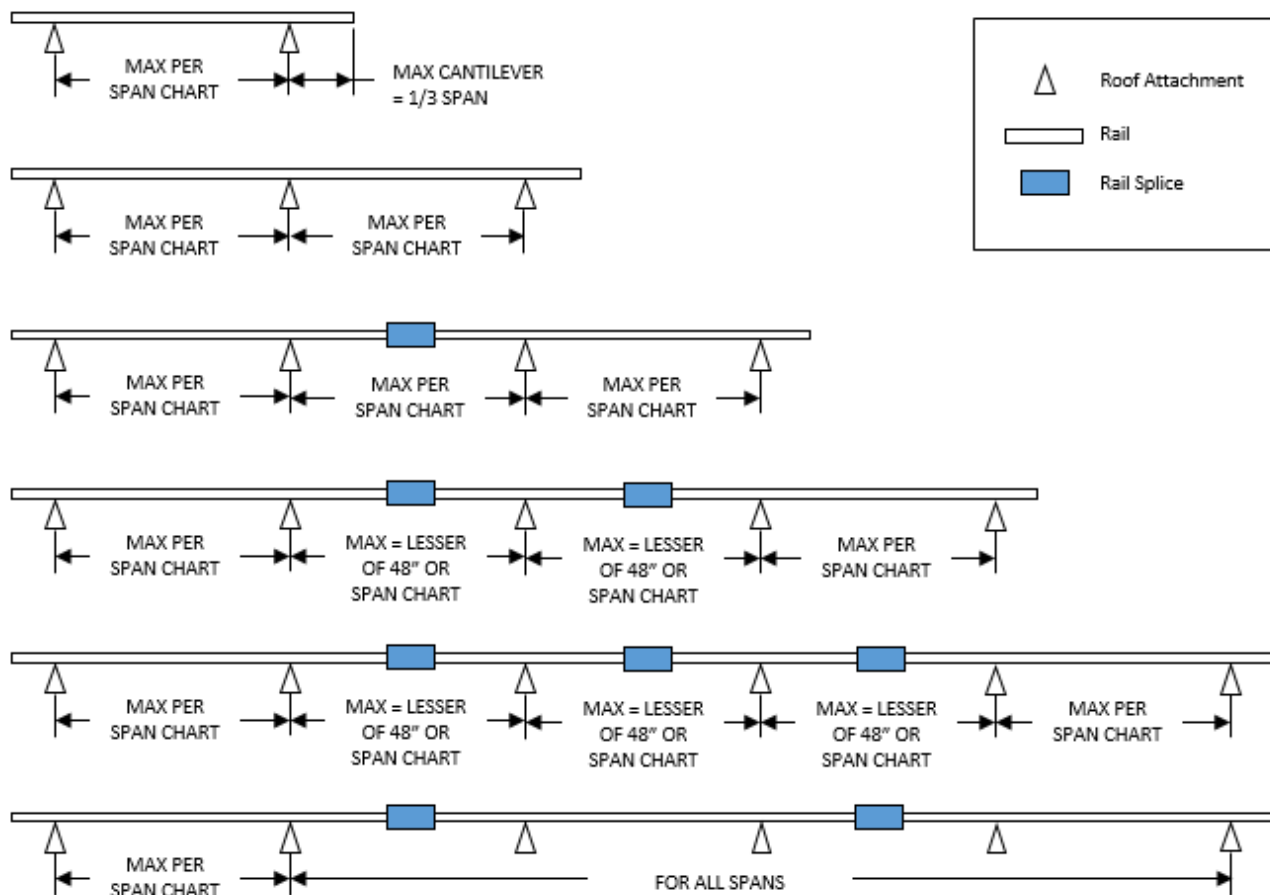

SMR Pitched Roof System



SMR Rail and Splice Use Cases (Continued):

- Rails installed with (2) Roof Attachments (1 rail span):
SMR Rail Splice where required shall be installed within a distance of $L/4$ from either Roof Attachment, where "L" is the rail span.
- Rails installed with (3) or more Roof Attachments (2 or more rail spans):
SMR Rail Splice where required shall not be installed within a distance of $L/8$ from any Roof Attachment, where "L" is the rail span.

Module Configuration:

With a full range of components, the SMR Pitched Roof System can be configured in an endless variety of designs. The system is IBC compliant for roof waterproofing, wind and wind driven rain tested, UL 1703 compliant for Class-A Fire Rated (Type 1 and 2) PV Modules and UL 2703 compliant for electrical bonding tested by ETL.

Proceed with the mounting of the PV panels using the roof attachment, Mid Clamps and End Clamps. Specific mounting instructions are shown in the following sections for portrait mounting.

A roof layout features two East-West rails. Mid Clamps are used between PV panels, they will produce 0.47" [12] spacing between PV panel frames. End Clamps are used to secure PV panels at the ends of a row.



SMR Pitched Roof System



MLPE Installation

Install the T-Bolt into the Rail in the desired location. Install the MLPE and secure using the hex nut. Use a 13mm hex socket and torque to 13Nm (10 ft-lbs).



Minimum Panel Height

Minimum leading-edge height to meet the UL1703 PV module fire standard is 3.0" [76.2mm].

3.0" [76.2mm] minimum
from bottom of PV module frame
to the roof covering

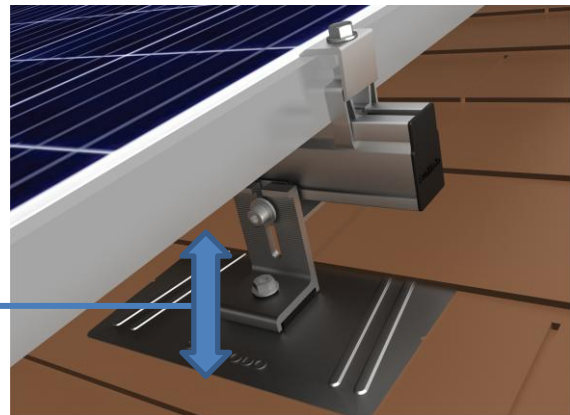

End Clamp Location

There must be a minimum of 1.5" [38.1mm] of Rail extending beyond the PV panel frame.

Secure the PV panel frame to the Rail using the End Clamp; use a 13mm hex socket and torque to 9.4 Nm (6.9 ft-lbs).

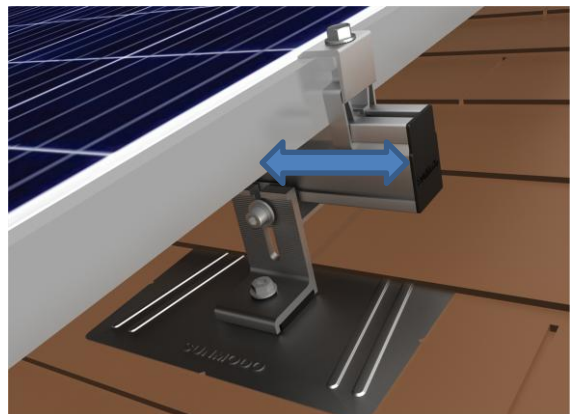

SMR Pitched Roof System

SMR End Clamp

Install the End Clamp on the Rail at the ends of the PV module array:

- Confirm that the hooks on the End Clamp are fully engaged with the hooks on the side of the Rail.
- Use your free hand to support the End Clamp against the panel frame while tightening.
- Use a 13mm hex socket and torque to 9.4 Nm (6.9 ft-lbs).

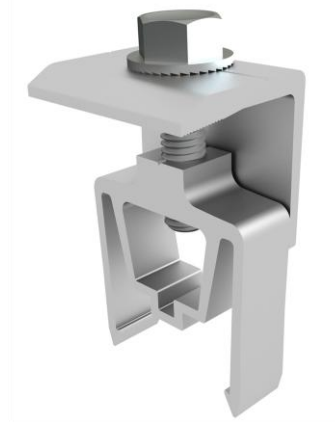

SMR Mid Clamp

The SMR self-bonding system is for use with PV modules that have a maximum series fuse rating of 30A.

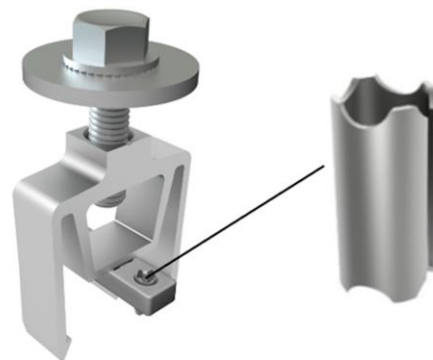

SMR Mid Clamp Attachment

Install the Mid Clamp on the Rail between PV panels.

- Confirm that the hooks on the Mid Clamp are fully engaged with the hooks on the side of the Rail.
- Secure the PV panel frame to the Rail using the Mid Clamp; use a 13mm hex socket and torque to 9.4 Nm (6.9 ft-lbs).

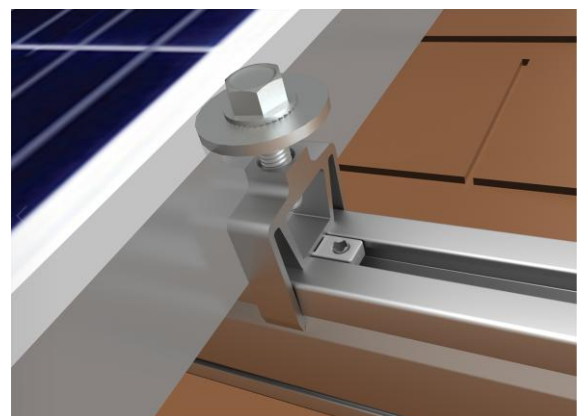

SMR Pitched Roof System



SMR100 Bottom Clamp

The SMR100 Bottom Clamp secures the PV panel frame flange to the Rail which allows the Rail to be cut flush with the module frame.



SMR100 Bottom Clamp Attachment

Install the SMR100 Bottom Clamp on the Rail at the ends of the PV panel array:

- Slide the SMR Bottom Clamp onto the Rail and pull forward to fully engage the panel frame flange.
- Use your free hand to support the Bottom Clamp against the panel frame flange while tightening.
- Use a 13mm hex socket and torque to 9.4 Nm (6.9 ft-lbs).

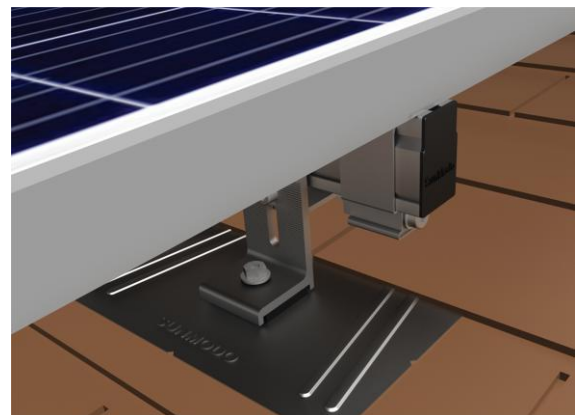

Ground Wire Attachment

The Ground Lug is intended for a single use after final torque values are reached and is designed to terminate or pass thru: #6 thru #12 AWG cable, either solid or stranded, including #6 thru #12 THHN or THWN jacketed cable.

See PV module's installation instructions when mounting the Ground Lug to the PV module.

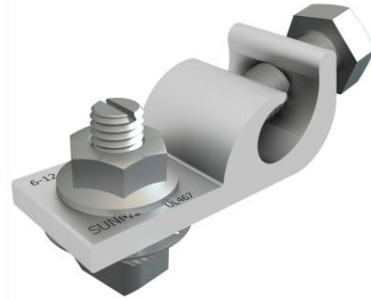

Ground Lug Installation

The picture shows a Ground Lug mounted on one Rail per row of panels.

Ground Lug K10179-001 and K10469-001 detailed installation document D10003 are available from SunModo separately.

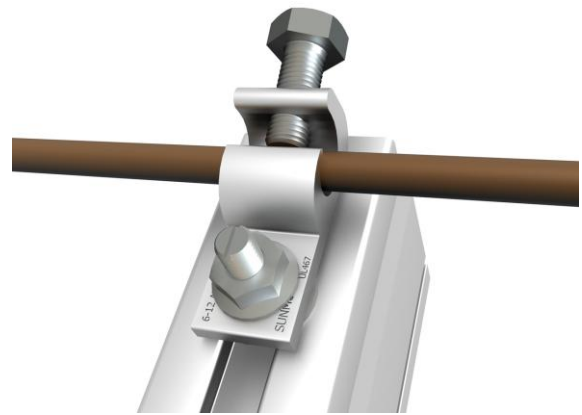

UL 2703 Label Placement

When requested the UL 2703 Label can be located on the Rail.

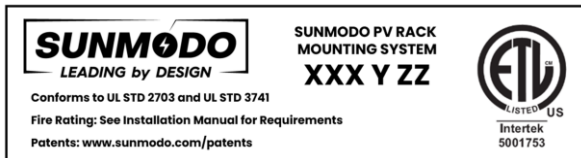

Date Code: Letters "XXX Y ZZ" are defined as follows:

- XXX shall be used to identify the Manufacturer.
- Y shall be used to identify the Quarter of the year manufactured, i.e., 1, 2, 3, 4.
- ZZ shall be the last 2 digits of the Year manufactured, i.e., 25, 26, 27.

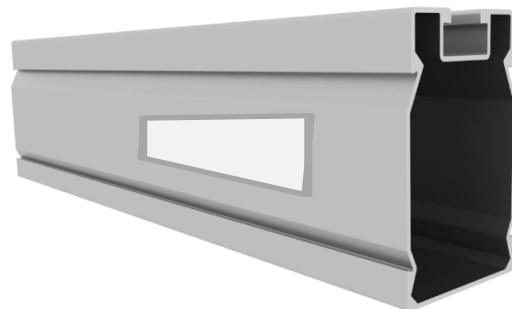

SMR Pitched Roof System



Wire Management Clip Installation

Install the Wire Management Clip into the top Rail channel and secure by locking into place.
Install PV wires, trunk cable, and other wires in the clip.

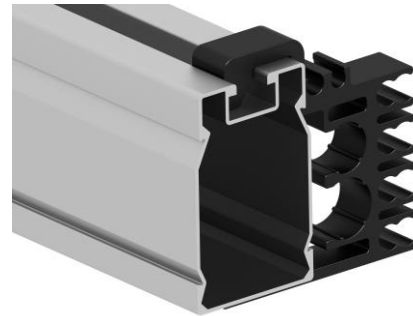

Rail End Cap Attachment

End Caps can be attached to the end of the Rail as shown.

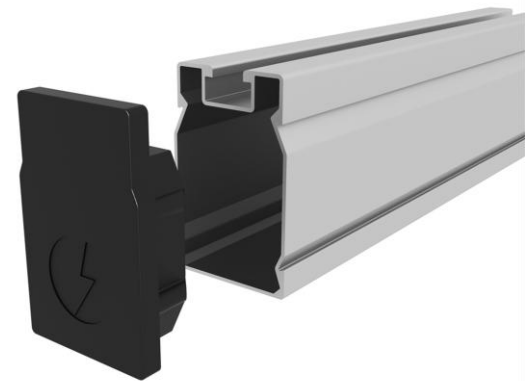

Conduit Clamp

Combine the Conduit Clamp with any L-Foot to create conduit supports in the desired locations.

