



# Tigo EI

## Residential Solar Solution

### US Installation Manual (w/ATS 50A)



Visit the Tigo Energy [Help Center](#) for comprehensive videos, articles, and other resources for all Tigo products.

## Disclaimer of Warranties and Limitation of Liability

The information, recommendations, descriptions, and safety disclosures in this document are based on Tigo Energy, Inc.'s ("Tigo") experience and judgment and may not cover all contingencies. If further information is required, consult a Tigo representative. Sale of the product shown in this document is subject to the terms and conditions outlined in Tigo's Limited Warranty, Terms and Conditions, and any other contractual agreements between Tigo and the purchaser.

THERE ARE NO UNDERSTANDINGS, AGREEMENTS, WARRANTIES, EXPRESSED OR IMPLIED, INCLUDING WARRANTIES OF FITNESS FOR A PARTICULAR PURPOSE OR MERCHANTABILITY, OTHER THAN THOSE SPECIFICALLY SET OUT IN ANY EXISTING CONTRACT BETWEEN THE PARTIES. ANY SUCH CONTRACT STATES THE ENTIRE OBLIGATION OF TIGO. THE CONTENTS OF THIS DOCUMENT SHALL NOT BECOME PART OF, OR MODIFY ANY CONTRACT BETWEEN, THE PARTIES.

In no event will Tigo be responsible to the purchaser or user in contract, in tort (including negligence), strict liability or otherwise for any special, indirect, incidental, exemplary, reliance or consequential damage or loss whatsoever, including but not limited to injury to persons, damage or loss of use of property, equipment or power systems, loss of profit, cost of capital, loss of power, additional expenses in the use of existing power facilities, or claims against the purchaser or user by its customers resulting from the use of the information, recommendations and descriptions contained herein. The information contained in this document is subject to change in Tigo's sole discretion and without notice.

## Document Version History

Version	Date	Changes
1.0	20230609	Initial release
1.1	20231012	Added IMPORTANT SAFETY INFORMATION and corrected the name and shutdown description in the <a href="#">Rapid Shutdown Switch</a> section.
1.2	20231204	Corrected Energy Meter <a href="#">Current Transformer Connections</a> instructions and diagram.
1.3	20240414	Added <a href="#">Reset Button</a> topic to EI Inverter section. Corrected current transformer arrow direction in Energy Meter <a href="#">Current Transformer Connections</a> . Reordered commissioning step for internet access in <a href="#">Select Equipment</a> .
1.4	20240924	Add Callout terminating plugs and commissioning on battery cabinet pg. 35 & pg. 44. Update TAP images on pg. 45. Callout on ATS on pg. 32 & 50
1.5	20240930	Clarified no. of battery connection pg. 39 & 41.

---

## Contents

Disclaimer of Warranties and Limitation of Liability .....	2
Document Version History.....	2
Contents .....	3
Overview .....	1
This Manual.....	2
IMPORTANT SAFETY INFORMATION.....	3
SAVE THESE INSTRUCTIONS .....	3
Pre-Installation.....	6
Location .....	6
Component Layout.....	6
Component Dimensions .....	7
Wiring Overview .....	7
Grid Connections .....	8
The EI Inverter .....	9
Box Contents .....	9
Enclosure Overview .....	9
MAC ID .....	9
DC Disconnect and Enclosure Knockouts.....	10
Reset Button .....	10
Status Indicators.....	11
Mounting.....	12
Communications Connections.....	13
Power Connections.....	17
Grounding Points .....	17
Wiring.....	18
Rapid Shutdown Switch .....	22
The Energy Meter.....	24
Mounting.....	24
Inverter Connections.....	24
Power Connections.....	25
Current Transformer Connections.....	26
LED Indicators .....	27

---

---

Power Status LED .....	27
L1/L2 Phase Status LED.....	27
Reset Button.....	27
The EI Automatic Transfer Switch (ATS).....	28
Box Contents .....	28
Enclosure Overview .....	28
Mounting.....	29
Wiring .....	30
Backup Load Connections .....	30
Grid Connections .....	31
Inverter Connections.....	32
The EI Battery.....	33
Box Contents .....	33
Enclosure Overview .....	33
Place and Prepare .....	34
Connect to the Inverter .....	36
Add Batteries .....	39
Status Indicators.....	43
Forced Start/Shutdown.....	44
TAP and TS4 MLPE .....	45
Install the Tigo Access Point (TAP) .....	45
Install TS4 MLPE .....	48
Commissioning .....	50
Check Connections .....	50
Power On the System .....	50
Run the Tigo Energy Intelligence App .....	51
Set System Info .....	51
Select Equipment.....	52
Configure Layout .....	56
Configure Communication.....	60
Set Up System Access .....	60
Reference .....	61
Error Codes .....	61

---

Inverter Warning Codes .....	61
Inverter Fault Codes .....	62
System Fault Codes.....	63
Decommissioning .....	64
Maintenance .....	64
Specifications.....	64
Warranty.....	64
Customer Support .....	65
Appendix A – UL 1741 PCS CRD Section 208 Information.....	66
Integrations.....	66
Time of Use.....	67
Self-Consumption.....	68
Backup.....	68
Zero Export .....	69
Appendix B – Configuring HECO Requirements.....	70

## Overview

The Tigo EI Residential Solar Solution optimizes home energy consumption based on rate plans and today's energy needs. It is built with the following components:

1. **EI Inverter** – A 3.8 kW or 7.6 kW hybrid inverter may be installed grid-tied only or as part of an energy storage system (ESS) when paired with up to four Tigo EI batteries.  
**Energy Meter** – This unit monitors energy generated by the system and supplied by the grid.
2. **TS4 MLPE** – Tigo's PV module-level power electronic (MLPE) components optimize solar module performance and provide module-level monitoring and rapid shutdown. A Tigo Access Point (TAP) with a wired connection to the inverter communicates with TS4 components wirelessly.
3. **EI Battery** – Up to four lithium-iron-phosphate (LFP) EI batteries are designed for use specifically with the EI solution.
4. **EI Automatic Transfer Switch (ATS)** – The ATS senses grid loss and safely switches from grid + solar/battery power to solar/battery power only.
5. The **Tigo Energy Intelligence** platform and mobile app enables easy system commissioning and provides comprehensive ongoing visibility into system and module performance.

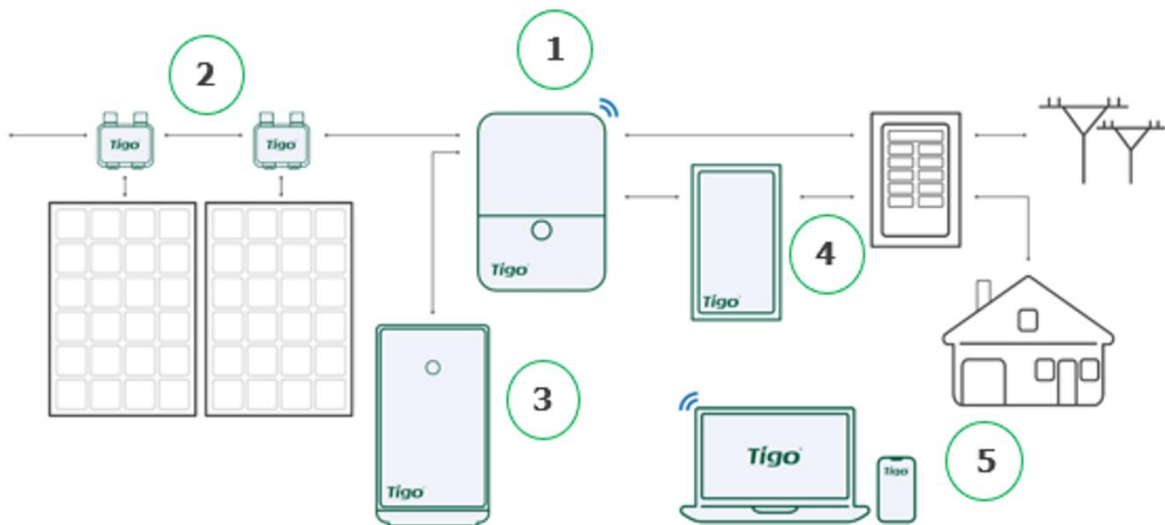

## This Manual

This manual provides instructions for installing the following components of a complete Tigo EI Residential Solution:

- EI Inverter
- Energy Meter
- EI ATS 50A
- EI Battery
- TS4 MLPE



If using an ATS 200A, refer to the *EI Residential Solar Solution US Installation Manual (w/ATS 200A)* on the [tigoenergy.com Downloads](https://www.tigoenergy.com/Downloads) page.

Special safety notifications in this manual are marked as follows:



**DANGER!**  
A situation involves risk of death or personal injury.



**CAUTION!**  
A situation risks damage to equipment or voiding warranty.

## IMPORTANT SAFETY INFORMATION

### SAVE THESE INSTRUCTIONS

Together, the Tigo EI Inverter with the provided rapid shutdown switch and TS4-A-O/S/F/2F MLPE enable a photovoltaic rapid shutdown system (PVRSS) as defined by NFPA 70, National Electrical Code (NEC).

Pushing the rapid shutdown switch button disconnects power to the inverter power-line communication (PLC) transmitter and any installed Tigo Access Points (TAP)s. This causes TS4 rapid shutdown devices to attenuate each solar module’s DC output to below 30 V within 30 seconds per rapid shutdown requirements.



**DANGER!**

Pulling the switch button out restores power connections to the transmitter and TAPs and returns the PV system to normal operation.

If not installed with TS4-A-O/S/F/2F MLPE connected to all solar modules:

**WARNING — THIS PHOTOVOLTAIC RAPID SHUTDOWN EQUIPMENT (PVRSE) DOES NOT PERFORM ALL OF THE FUNCTIONS OF A COMPLETE PHOTOVOLTAIC RAPID SHUTDOWN SYSTEM (PVRSS). THIS PVRSE MUST BE INSTALLED WITH OTHER EQUIPMENT TO FORM A COMPLETE PVRSS THAT MEETS THE REQUIREMENTS OF NEC (NFPA 70) SECTION 690.12 FOR CONTROLLED CONDUCTORS OUTSIDE THE ARRAY. OTHER EQUIPMENT INSTALLED IN OR ON THIS PV SYSTEM MAY ADVERSELY AFFECT THE OPERATION OF THE PVRSS. IT IS THE RESPONSIBILITY OF THE INSTALLER TO ENSURE THAT THE COMPLETED PV SYSTEM MEETS THE RAPID SHUTDOWN FUNCTIONAL REQUIREMENTS. THIS EQUIPMENT MUST BE INSTALLED ACCORDING TO THE MANUFACTURER’S INSTALLATION INSTRUCTIONS.**

In addition:

- This manual contains important instructions for installation and maintenance of the Tigo EI Inverter, ATS 200A, and EI Battery.
- Trained professionals must perform installation only. Tigo does not assume liability for loss or damage resulting from improper handling, installation, or misuse of products.
- Before installing or using the Tigo system, please read all instructions and warning markings on the components and this installation manual.
- Check specifications for all components in the [Specifications](#) section of this manual.
- Components must operate within the technical specifications listed in their [data sheets](#).
- Use only copper conductors rated 75 °C or higher. Do not use fine-stranded conductors.
- Unused conduit openings must be properly sealed and connected conduit must use appropriate fittings. Tigo EI product enclosures are rated IP65.
- Always wear appropriate PPE and use insulated tools.
- This product could expose the user to chemicals known to the State of California to cause cancer. For more information refer to [www.P65Warnings.ca.gov](http://www.P65Warnings.ca.gov).

- The inverter has no isolation transformer, and it must be installed with an ungrounded PV array in accordance with NEC 690.35 and 690.43.
- To reduce risk of fire and shock hazard, install this device with strict adherence to National Electric Code (NEC) ANSI/NFPA 70 and/or local electrical codes. When the photovoltaic array is exposed to light, it supplies a DC voltage to the Tigo TS4 units and the output voltage may be as high as the PV module open circuit voltage ( $V_{oc}$ ) when connected to the module. The installer should use the same caution when handling electrical cables from a PV module with or without the TS4 units attached.
- TS4-A-F and TS4-A-2F MLPE are shipped in the OFF position and will measure 0.6V at the output when the keep-alive signal is not present.
- Do not operate Tigo components if they have been physically damaged. Check existing cables and connectors, ensuring they are in good condition and appropriate in rating. Do not operate Tigo TS4 components with damaged or substandard wiring or connectors.
- Do not connect or disconnect TS4s under load. Turning off the inverter and/or the Tigo products may not reduce this risk. Internal capacitors within the inverter can remain charged for several minutes after disconnecting all power sources. Verify capacitors have discharged by measuring voltage across inverter terminals prior to disconnecting wiring if service is required. Wait 30 seconds after rapid shutdown activation before disconnecting DC cables or turning off the DC disconnect.
- Connectors from different manufacturers cannot be mated with each other.
- All AC and DC connections must use provided ferrules installed with an appropriate ferrule crimping tool.
- The capacity of a lithium-iron-phosphate (LFP) EI Battery module is 3.3 kWh and the nominal voltage 51.2 V.

**DANGER!**

The inverter DC disconnect switch must be OFF for five minutes before opening the inverter cover.

These symbols may appear on Tigo enclosures:



Risk of electrical shock.



Risk of burns.



Check the operating instructions.



Caution, the inverter may retain high voltage for up to five minutes after disconnection.



Avoid tampering.



Observe caution.



Grounding connection.

## Pre-Installation

---

### Location

EI enclosures are NEMA 4/IP65 rated for indoor and outdoor exposure. To optimize performance and extend service, locate the enclosures:

- In a well-ventilated, easily accessible location.
- On a flat surface against a solid wall with  $\leq 15^\circ$  tilt.
- Sheltered from direct sunlight and excessive moisture. The ambient temperature is ideally below 50 °C.
- Away from antennas or other sources of electromechanical interference.
- Above potential flooding.

### Component Layout

Follow these guidelines when planning how to mount components:

#### **Inverter**

- As close as possible to the main service panel to minimize AC voltage drop.
- At least 3 m (36 in.) above the ground.
- With a minimum 300 mm (12 in.) clearance around the top and sides.

#### **Rapid shutdown switch**

- Adjacent to the inverter and service entrance.
- Clearly visible and accessible to first responders and maintenance workers.

#### **Energy Meter**

- In an AC load center or other outdoor enclosure adjacent to the inverter and main panel.

#### **ATS**

- Adjacent to the inverter and main panel.
- With a minimum 300 mm (12 in.) clearance around all sides.

#### **Battery**

- On level ground.
- With a minimum 914 mm (36 in.) side and top clearance from other system enclosures/objects.

## Component Dimensions

Plan to accommodate the following approximate dimensions (width/height/depth):

Component	Width/Height/Depth	Weight
Inverter 3.8/7.6 kW	400 x 570 x 170 mm (15.75 x 22 x 6.7 in.)	14.6 kg (32.3 lb.)
Energy Meter	54.1 x 87.8 x 52 mm (2.1 x 3.5 x 2.0 in.)	0.2 kg (0.44 lb.)
ATS 50A	275 x 480 x 105 mm (10.8 x 18.9 x 4.1 in.)	15 kg (33 lb.)
Battery	650 x 1160 x 320 mm (25.6 x 45.7 x 12.6 in.)	140 kg (308.6 lb.)

## Wiring Overview

The EI system can operate on 208 or 240 V at 60 Hz. For detailed wiring instructions, refer to the following [EI Inverter](#), [EI ATS](#), [TAP and TS4 MLPE](#), and [EI Battery](#) sections.

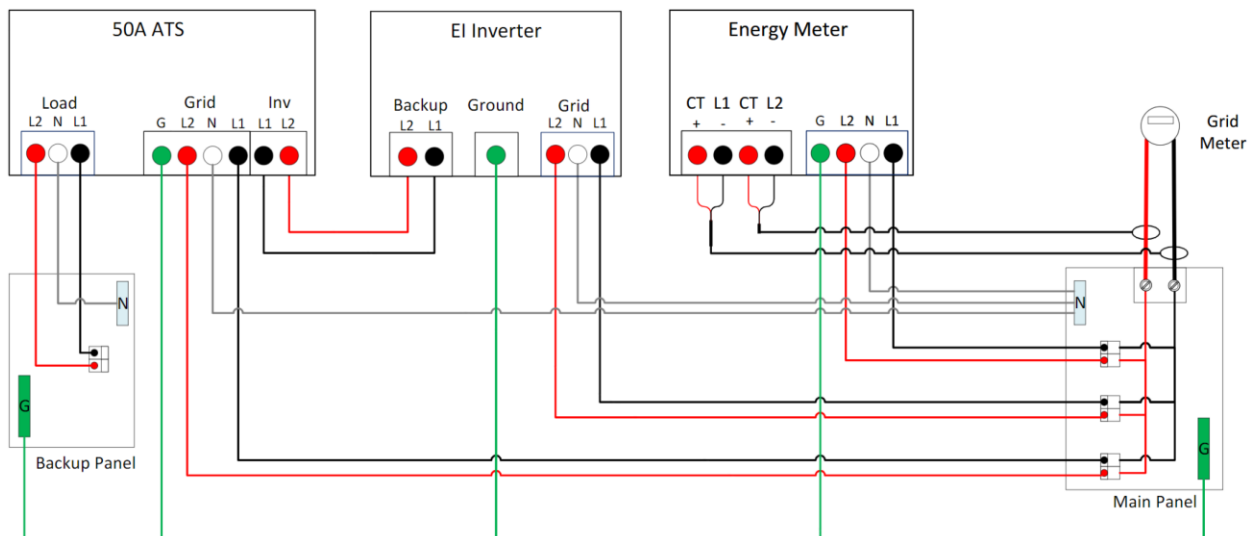

### Grid Connections

EI Inverters are grid-tied to the public utility grid and the grid voltage is chosen through the EI app. The following shows the types of grid connections supported by EI Inverters.

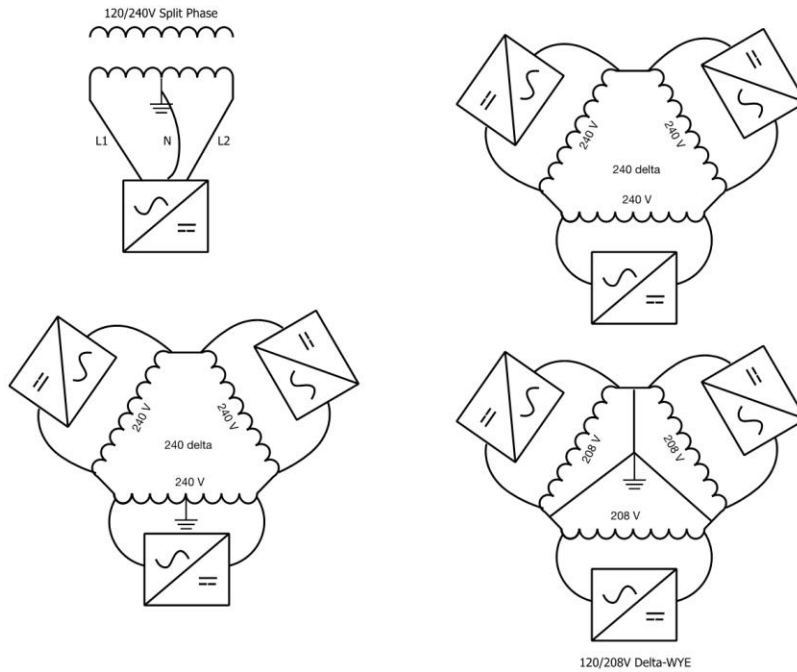

## The EI Inverter

This section includes:

- Box Contents
- Enclosure Overview
- Mounting
- Communications Connections
- Power Connections
- Rapid Shutdown Switch

For detailed specifications, download the EI Inverter data sheet from the [tigoenergy.com Downloads](https://www.tigoenergy.com/Downloads) page.

### Box Contents

The EI Inverter box includes:

- EI Inverter
- Quick Start Guide
- Mounting bracket
- Tigo Access Point (TAP)
- Rapid shutdown label
- Rapid shutdown switch
- DC wire ferrules (3.8 kW: 12, 7.6 kW)
- AC wire ferrules (5)
- 3-pin plug for RS-485 Energy Meter communications connection
- Grounding ring terminal
- Hex-head self-tapping screws (inverter mounting, 5)
- Philips-head screw (rapid shutdown switch mounting, 4)
- White wall anchors (inverter, 5)
- Green wall anchors (rapid shutdown switch, 4)
- Wi-Fi antenna
- Cellular antenna (only with cell-enabled models)
- 0.875 in. OD knockout for 0.5 in. plug with nut
- 1.375 in. OD knockout for 1 in. plug (2)
- 1.375 in. OD knockout for 1 in. plug with nut (2)

### Enclosure Overview

#### *MAC ID*

A label with the inverter's MAC ID and a [tigoenergy.com](https://www.tigoenergy.com) QR code is located on the left side below the specifications label.

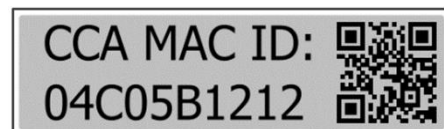

### DC Disconnect and Enclosure Knockouts

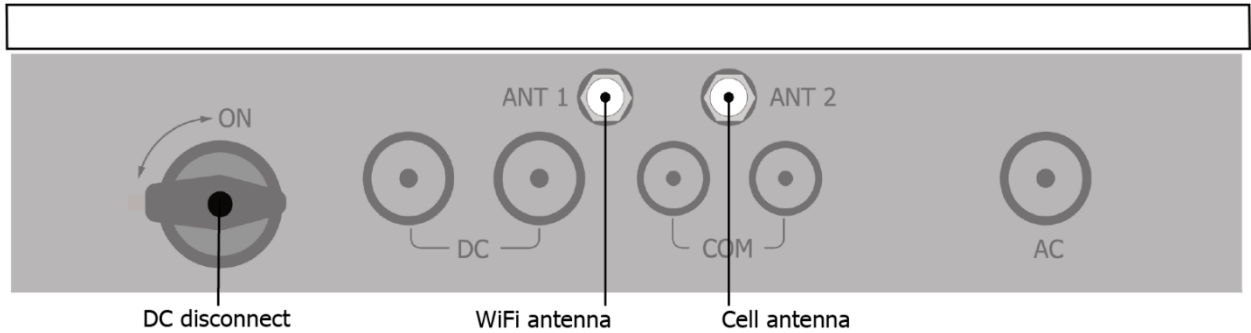

### Reset Button

A reset button is located on the top right of the inverter’s communications board. This button performs multiple functions as described below in Table 16.

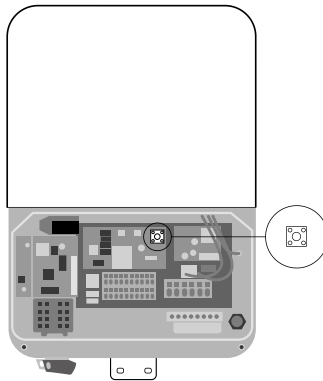



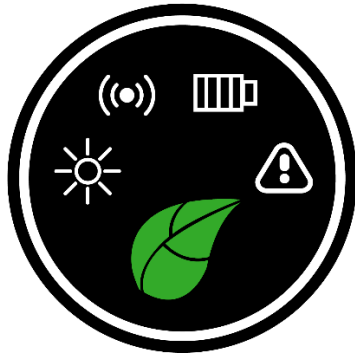

- To clear an arc fault notification, press the button for 3 – 5 secs.
- To run an arc fault self-test when no arc fault alarm is present, press the button for 3 – 5 secs.
- To reset communications to factory status, press the button for >10 secs.

### Status Indicators

The status indicator LEDs in the center of the inverter front panel show the EI system’s current operating conditions.



Symbol	Action	Description
 Power	Continuous	Feed in grid
	Flashing 3 sec. on/1 sec. off	DC on/AC off
	Flashing 1 sec. on/3 sec. off	DC off/AC on
	Flashing 0.5 sec. on/0.5 sec. off	Checking
	Flashing 2 sec. on/2 sec. off	Standby mode
	Off	Disconnected
 Communications	Continuous	4G/Wi-Fi, local Wi-Fi ok
	Flashing 0.5 sec. on/0.5 sec. off	Local Wi-Fi connecting
	Flashing 1 sec. on/1 sec. off	4G/Wi-Fi failure, local Wi-Fi ok
	Flashing 1 sec. on/3 sec. off	Local Wi-Fi failure, 4G/Wi-Fi ok
	Off	Failure
 Battery	Continuous	Operating normally
	Flashing 1 sec. on/3 sec. off	Low charge state
	Flashing 0.5 sec. on/0.5 sec. off	Fault detected
	Off	Disconnected
 Fault	Continuous with audible alarm	Arc fault
	Continuous	Fault
	Flashing 1 sec. on/1 sec. off	Warning
	Off	No faults detected

## Mounting

To mount the inverter:

1. Choose a location on a plumb wall with adequate clearance, free from direct sun and precipitation.

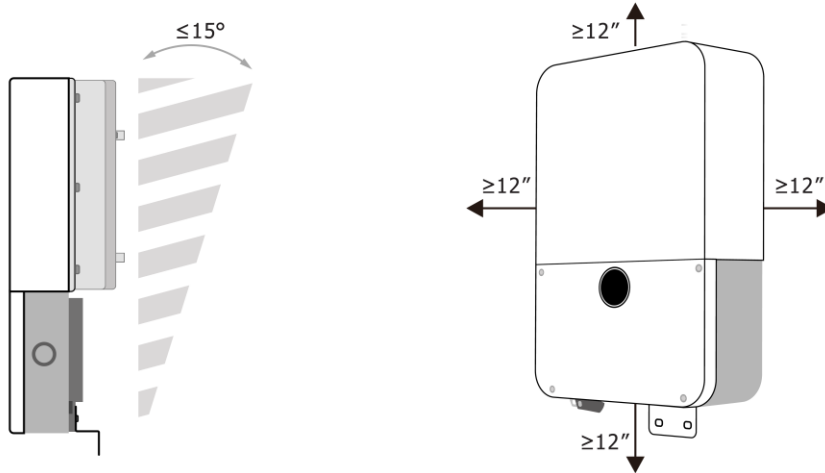

2. Affix the inverter top bracket using screws appropriate for the wall surface.

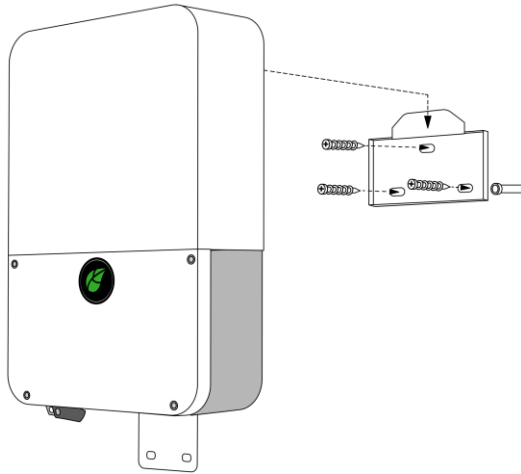

3. Hang the inverter on the bracket and affix the bottom bracket.

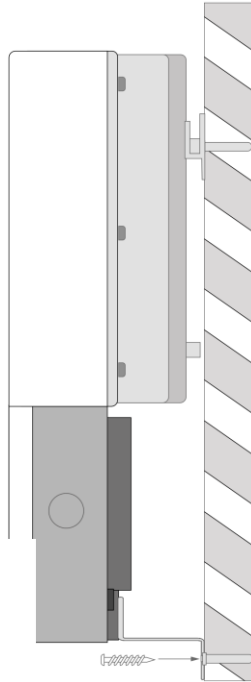

## Communications Connections



### CAUTION!

You must make communications connections to the TAP (if used), Energy Meter, and battery for the EI system to operate as an energy storage system (ESS).

Inverter communications connections include:

- An antenna to connect to a Wi-Fi or cell network.
- A wired connection to the TAP (if used).
- Wired connections to the Energy Meter and battery.

To connect an antenna:

- Attach the provided Wi-Fi or cell antenna to the appropriate inverter *ANT 1* (left, Wi-Fi) or *ANT 2* (right, cell) port on the bottom of the inverter.

To connect to a TAP when used with TS4-O/S/M MLPE:

1. Prepare a 4-wire or CAT5/6 cable:
  - Shielded if running next to PV conductors
  - 20 – 18 AWG or CAT5/6 twisted pairs
  - Solid core
  - Cable outside diameter (OD)  $\leq 9$  mm (.35 in.)
2. Connect the cable to the left side of the nearest TAP using either the quick-connect (4-wire) or the terminal block (4-wire or CAT5/6).

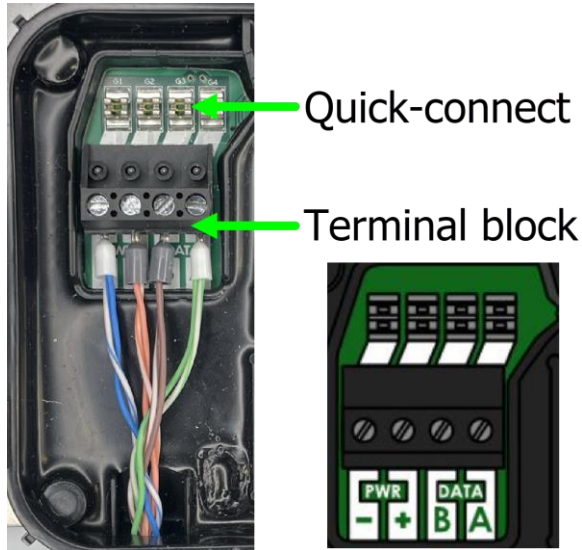

3. At the inverter, terminate the wires at the 4-pin TAP plug from bottom to top: -, +, Data B, Data A.

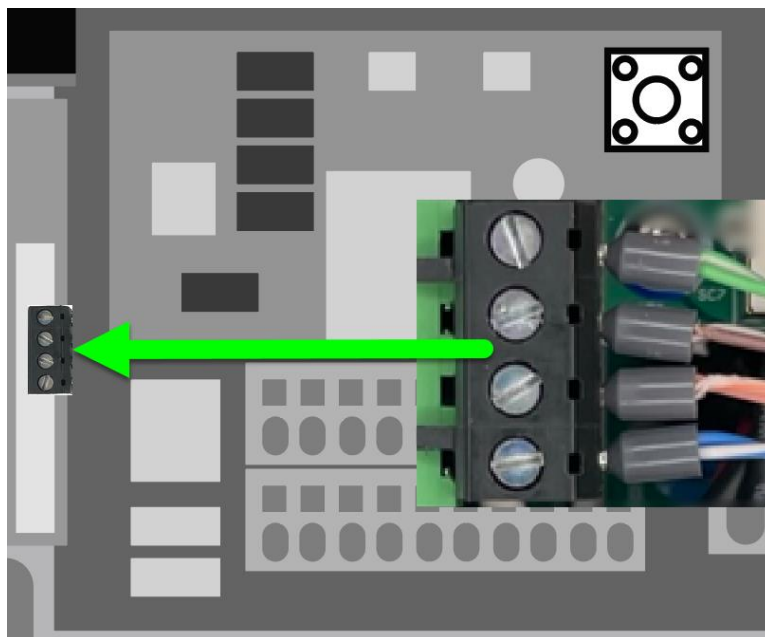

To connect to the Energy Meter:

1. Prepare a 3-wire shielded, twisted pair, 24-18 AWG RS-485 cable.
2. Locate the 3-pin plug included in the EI Inverter *Accessories* bag.
3. At the inverter, connect the RS-485 wires to the *A*, *G*, and *B* terminals on the 3-pin plug and install the plug.
4. At the Energy Meter, connect the RS-485 wires to the *G*, *B*, and *A* terminals.

**Inverter**

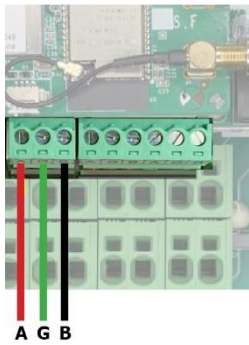

**Energy Meter**

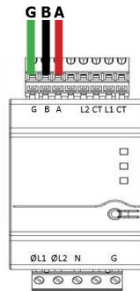

To connect to the battery:

1. In the battery's inverter connection wirebox on the left side of the enclosure, plug a CAT5/6 cable into the *COM INV* terminal.
2. At the inverter, plug the cable into the battery COM terminal.

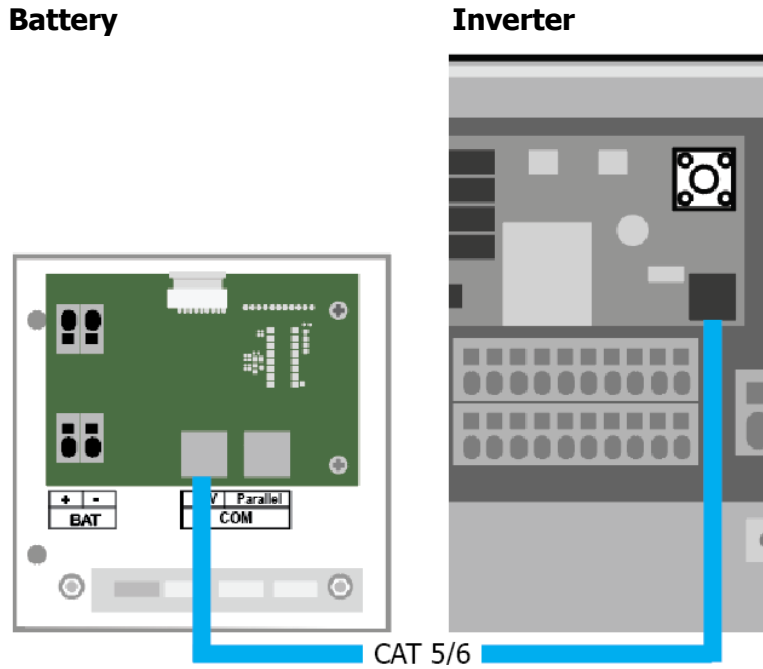

To connect COM cables to multiple batteries, refer to the [EI Battery](#) section.

## Power Connections



**DANGER!**

Ensure the inverter DC disconnect switch is OFF before making connections.

### *Grounding Points*

Equipment grounding conductor (EGC):

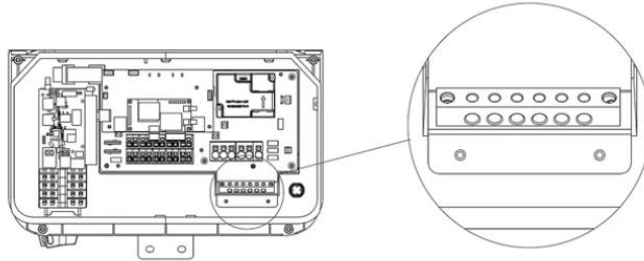

Grounding electrode conductor (GEC):

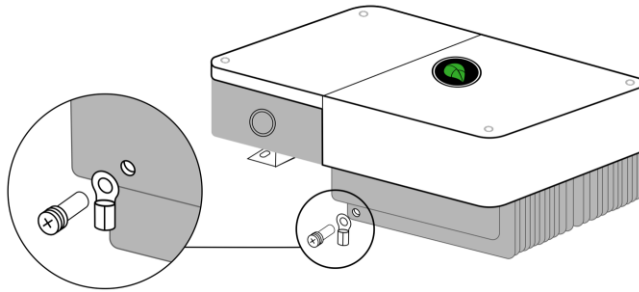

### Wiring

Prepare ferruled conductors using copper, non-fine-stranded wire:

- Enclosure grounding: 10 – 8 AWG
- AC (grid or ATS): 8 – 6 AWG
- DC (PV): 12 – 8 AWG
- DC (battery): 12 – 8 AWG



**DANGER!**

Always calculate conductor AWG based on wire length and current load.

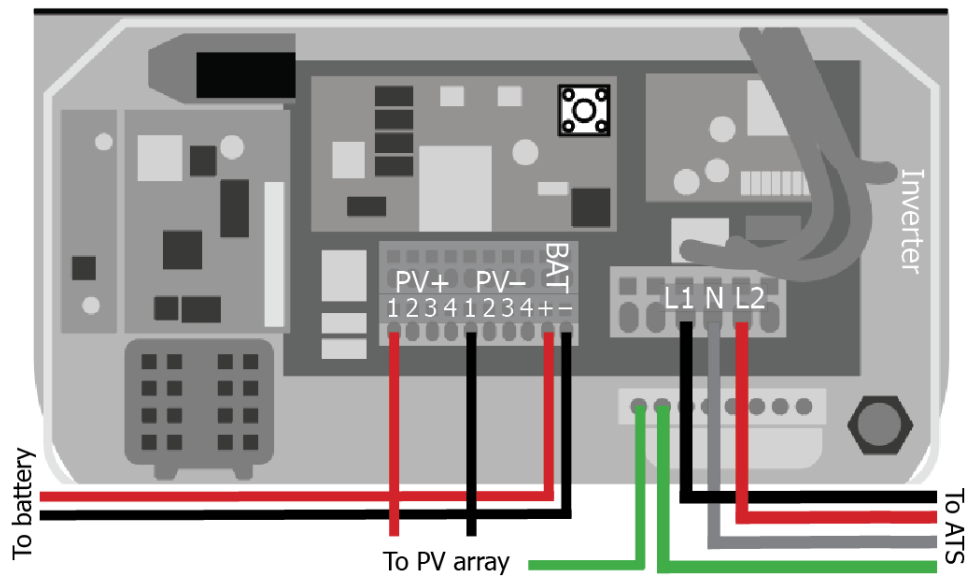

To connect to the grid or ATS:

1. Connect conductors to the inverter *GRID L1* and *L2* terminals and the ground bar.
2. If not using an ATS/battery and connecting directly to the grid, terminate conductors at the main load/service panel:
  - 3.8 kW inverter: 20 A 2-pole breaker
  - 7.6 kW inverter: 40 A 2-pole breaker
3. At the ATS, connect conductors to the *INPUT INV L1* and *L2* terminals and the ground bar.

**Inverter**

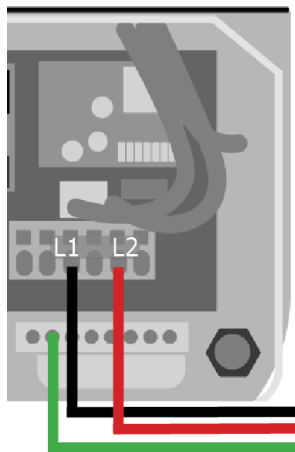

**ATS**

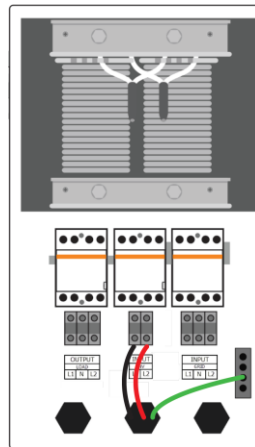

To connect PV strings:

1. Ensure TS4s are properly connected to their PV strings.



**CAUTION!**

The voltage of each PV string must be less than 600 V<sub>DC</sub>.  
Neither positive nor negative conductors can be grounded.

2. Connect conductors to the inverter:
  - 3.8 kW (2 MPPT) inverter: up to two strings
  - 7.6 kW (3 MPPT) inverter: up to three strings
3. Connect the PV array rack EGC to the inverter EGC busbar.

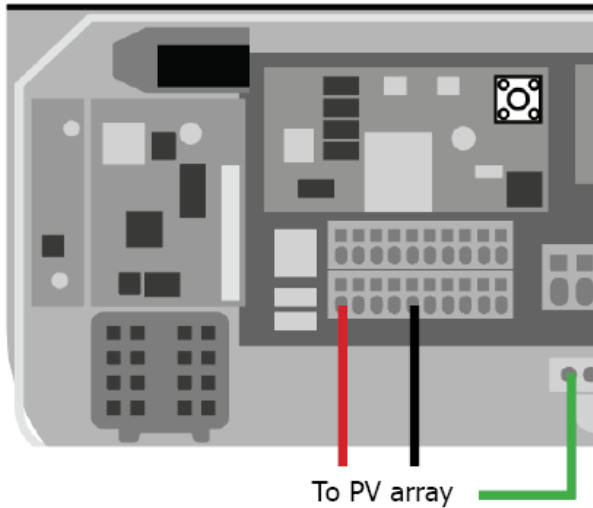

**To connect to a battery:**

1. In the battery's inverter connection wirebox, connect two  $\leq 2$  m (79 in.) conductors to the *BAT+* and *BAT-* terminals.
2. Connect the conductors to the inverter *BAT+* and *BAT-* terminals.

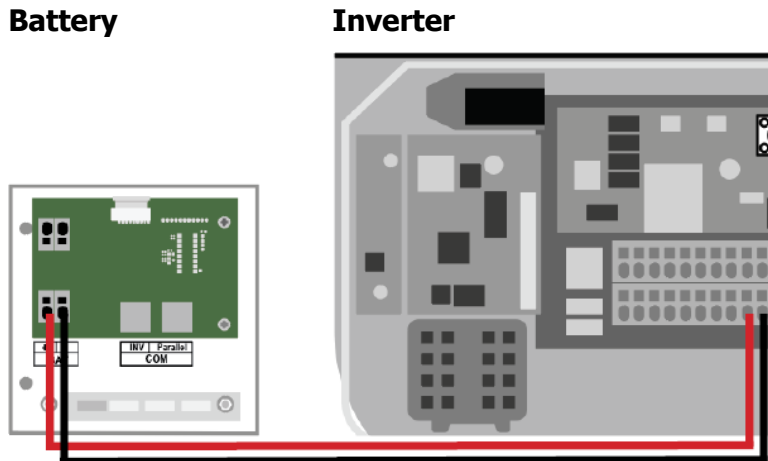

For details on how to add more batteries, refer to the [EI Battery](#) section.

## Rapid Shutdown Switch

Together, the Tigo EI Inverter with the provided rapid shutdown switch and TS4-A-O/S/F/2F MLPE enable a photovoltaic rapid shutdown system (PVRSS) as defined by NFPA 70, National Electrical Code (NEC).

Pushing the rapid shutdown switch button disconnects power to the inverter power-line communication (PLC) transmitter and any installed Tigo Access Points (TAP)s. This causes TS4 rapid shutdown devices to attenuate each solar module's DC output to below 30 V within 30 seconds per rapid shutdown requirements.



### CAUTION!

Use only the rapid shutdown switch provided with the Tigo EI Inverter.



### DANGER!

Pulling the switch button out restores power connections to the transmitter and TAPs and returns the PV system to normal operation.

To install the switch:

1. Mount the switch within 1 m (3 ft.) of the inverter or service entrance outside the residence.  
It must be clearly visible and accessible to first responders and maintenance workers.
2. At the inverter, remove the 3-pin connector from the CN14 port.
3. Connect two 22 – 18 AWG conductors to the 3-pin connector in positions 1 and 3 (position 2 is open). Polarity is not important.
4. Route the conductors to the switch and connect them to the two switch terminals.

### Inverter

### Rapid shutdown switch

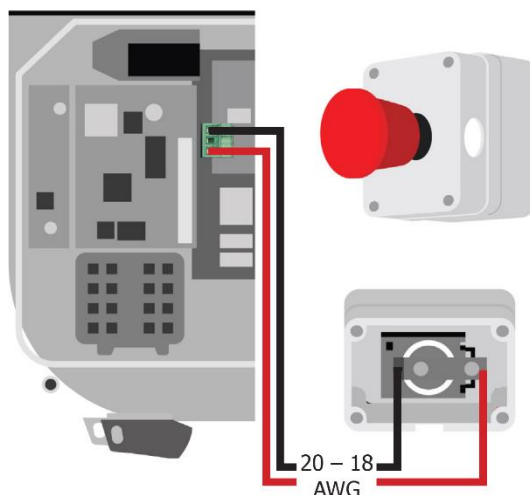

Affix the rapid-shutdown-equipped label to the service equipment location.

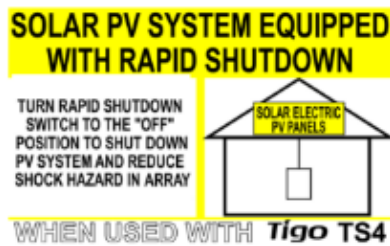

To connect a switch to multiple inverters, daisy-chain two 20 – 18 AWG wires to connect inverter switch terminals to the rapid shutdown switch.

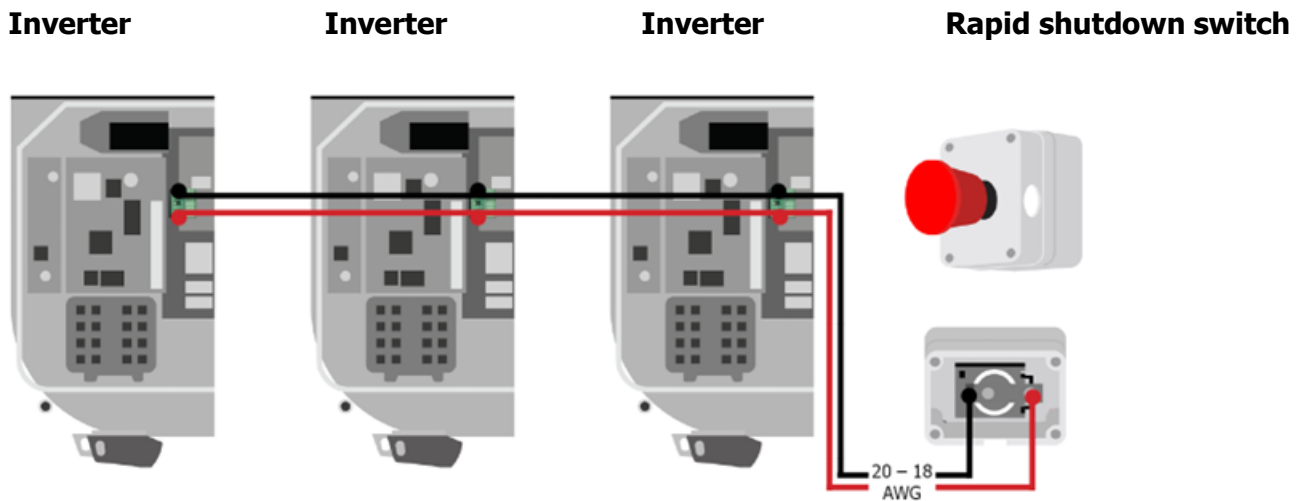

## The Energy Meter

This section includes:

- Mounting
- Inverter Connections
- Power Connections
- Current Transformer Connections
- LED Indicators

For detailed specifications, download the Energy Meter data sheet from the [tigoenergy.com Downloads](http://tigoenergy.com/Downloads) page.

### Mounting

Mount the meter in an AC load center or other NEMA 4 outdoor enclosure. The meter clamps to a 35 mm DIN rail.



**DANGER!**

Ensure all power to the AC load center and inverter are OFF before making connections.

### Inverter Connections

To connect the Energy Meter to the inverter:

1. Prepare a 3-wire shielded, twisted pair, 24-18 AWG RS-485 cable.
2. Locate the 3-pin plug included in the EI Inverter *Accessories* bag.
3. At the inverter, connect the RS-485 wires to the *A*, *G*, and *B* terminals on the 3-pin plug and install the plug.
4. At the Energy Meter, connect the RS-485 wires to the *G*, *B*, and *A* terminals.

#### Inverter

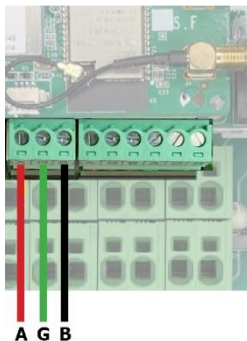

#### Energy Meter

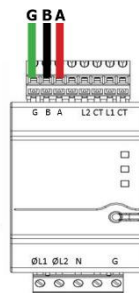

## Power Connections

To connect the meter to the AC load center:

1. Prepare stranded, 600 V, 22 – 18 AWG conductors.
2. At the load center, connect conductors to a double-pole circuit breaker rated for 20 A or less.

The meter draws 10 – 30 mA current. If using a neutral conductor, the breaker must interrupt both neutral and ungrounded conductors simultaneously.

3. At the Energy Meter, connect the RS-485 wires to the  $\emptyset L1$ ,  $\emptyset L2$ ,  $N$ , and  $G$  terminals. Tighten set screws to 0.4 Nm.

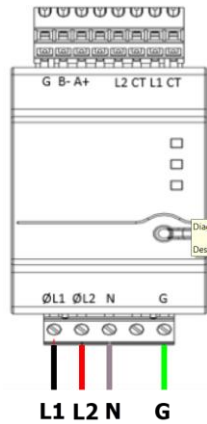

## Current Transformer Connections

To install current transformers (CTs):

1. Place a split-core CT around the L1 power conductor running from the load center to the grid meter.  
The arrow should point away from the grid.

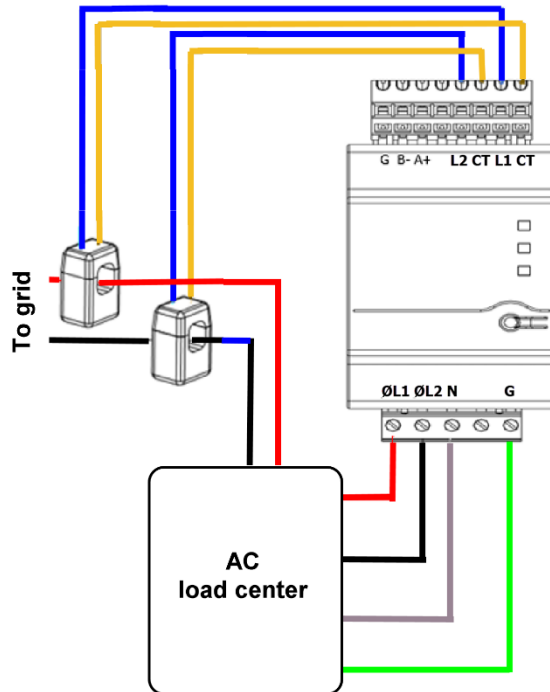

Optionally, use a nylon cable tie around the CT to prevent accidental opening.

2. Connect the blue and brown CT wires to the L1 and CT terminals at the top of the meter.
3. Place the other CT around the L2 power conductor with the arrow pointing away from the grid.
4. Connect its blue and brown wires to the L1 and CT terminals at the top of the meter.

## LED Indicators

Three status LEDs on the front face of the meter indicate power status, L1 phase status, and L2 phase status. At normal startup when power is first applied, all LEDs will light up sequentially for one second.

### *Power Status LED*

Activity	Indication	Troubleshooting
Green – flashing on/off 1 sec.	Normal	
Red – on for <3 sec.	Internal error	Contact the Tigo Help Center.
Yellow – flashing on/off 1 sec.	No communication	Check inverter communication connections.

### *L1/L2 Phase Status LED*

Activity	Indication	Troubleshooting
Green – on for <3 sec.	No current	Check power supply.
Green – flashing on/off 1 sec.	Positive power	
Red – flashing on/off 1 sec.	Negative power	If current direction appears incorrect, check for reversed CT wires or CTs not matched with lines.
Red/green flashing	High voltage >130 V	Check line voltages and meter rating.
Red/yellow flashing	Low voltage <70 V	Check line voltages and meter rating.
Yellow – flashing on/off 1 sec.	Break fault <30 V	Check line voltages and meter rating.
Yellow – on for <3 sec.	Frequency is <45 Hz or >70 Hz	Check for high noise.

## Reset Button

To update meter firmware, contact Tigo [Support](#).

# The EI Automatic Transfer Switch (ATS)

This section includes:

- Box Contents
- Enclosure Overview
- Mounting
- Wiring
- Status Indicators

For detailed specifications, download the ATS data sheet from the [tigoenergy.com Downloads](http://tigoenergy.com/Downloads) page.

Some of the connections described in this section may duplicate instructions included in other component sections in this manual.

## Box Contents

The ATS box includes:

- Quick Start Guide
- Sleeve anchors (3)
- Mounting screws (2)
- O-type terminals (3)
- Wire ferrules (9)
- Keys (2)
- Mounting bracket

## Enclosure Overview

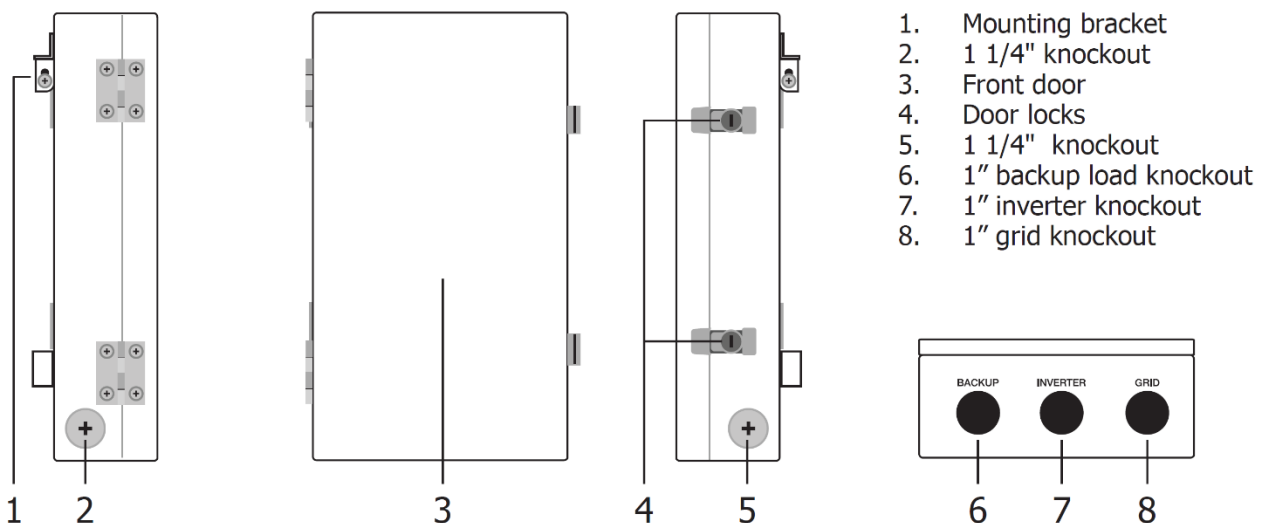

## Mounting

To mount the ATS:

1. Choose a location on a plumb wall with greater than 12in clearance and free from direct sun and precipitation.

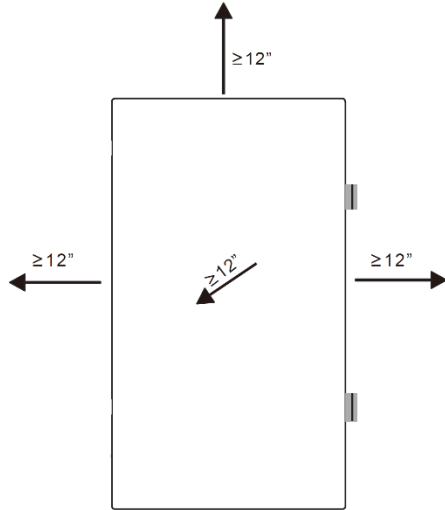

2. Use screws appropriate for the wall surface to affix the bracket and hang the ATS.

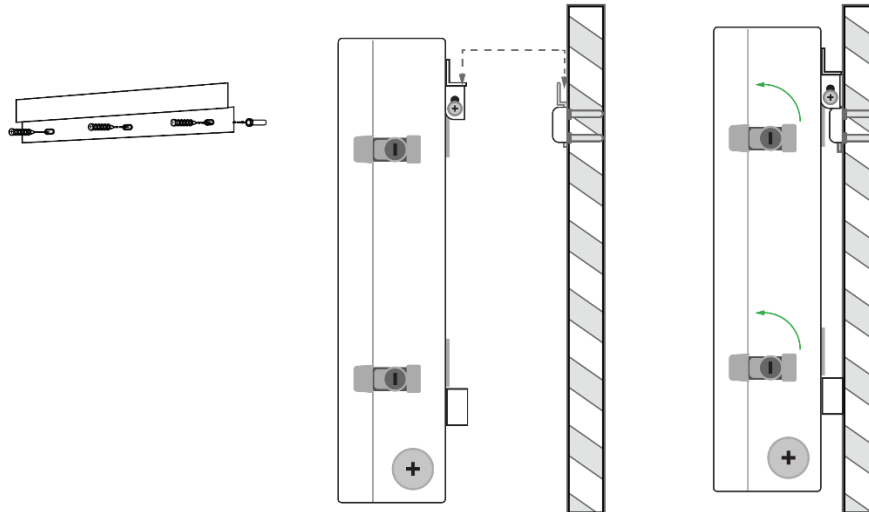

## Wiring

AC conductors must be ferruled copper, 90 °C rated, non-fine stranded, 8 – 6 AWG.



**DANGER!**

Always calculate conductor AWG based on wire length and current load.

### *Backup Load Connections*

To connect the ATS to the backup load panel:

1. Connect L1, N, L2, and ground conductors to the *OUTPUT LOAD L1, N, and L2* terminals and the ground bar. Torque to 22.5 Nm.

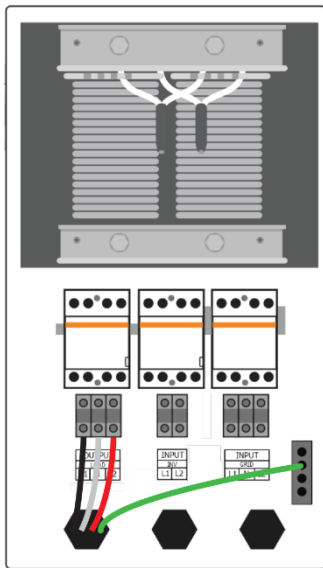

2. Terminate conductors at the backup load panel.

### Grid Connections



#### DANGER!

This connection carries power between the utility grid and the ATS. Direct connection to utility feeders or a line side may require coordination with the local utility.

To connect the ATS to the main panel:

1. Connect L1, N, L2, and ground conductors to the *INPUT GRID L1, N, and L2* terminals and the ground bar. Torque to 22.5 Nm.

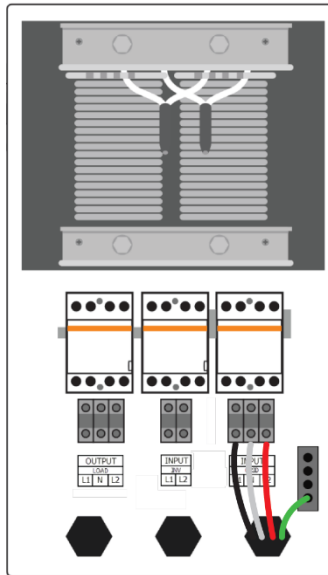

2. Terminate conductors at the main panel with a 50 A breaker.

### Inverter Connections

To connect to the inverter *GRID* terminals:

1. Connect conductors to the inverter *GRID L1* and *L2* terminals and the ground bar.
2. At the ATS, connect conductors to the *INPUT INV L1* and *L2* terminals and the ground bar.

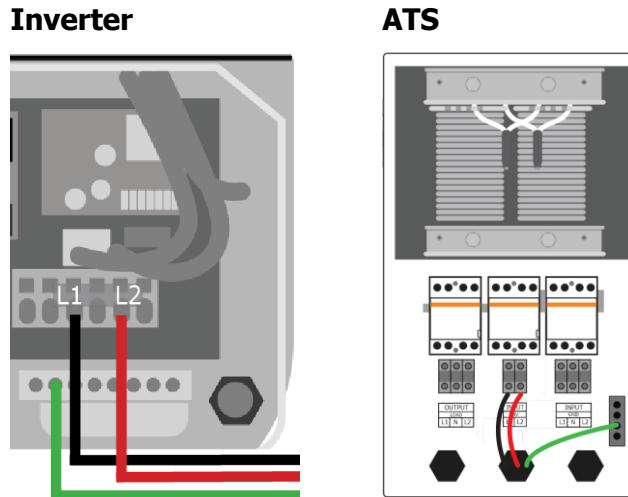

### CAUTION!



- Bypass Jumper is extremely important during Commissioning
- The ATS 50 Amp bypass jumper is required upon first startup of the ATS
- Please follow the instructions for Manually Bypassing the ATS

## The EI Battery

An EI system may include one, two, or four battery enclosures. This section includes:

- Box Contents
- Enclosure Overview
- Place and Prepare
- Connect to the Inverter
- Add Batteries

For detailed specifications, download the EI Battery data sheet from the [tigoenergy.com Downloads](http://tigoenergy.com/Downloads) page.

Some of the connections described in this section may duplicate instructions included in other component sections in this manual.

### Box Contents

The EI Battery box includes:

- Battery enclosure
- Quick Start Guide
- Security screws (6)
- Sleeve anchors (2)
- Wire ferrules (4)

Battery modules are packaged separately and include two RJ45 terminators. One loose cable is included within the battery enclosure.

### Enclosure Overview

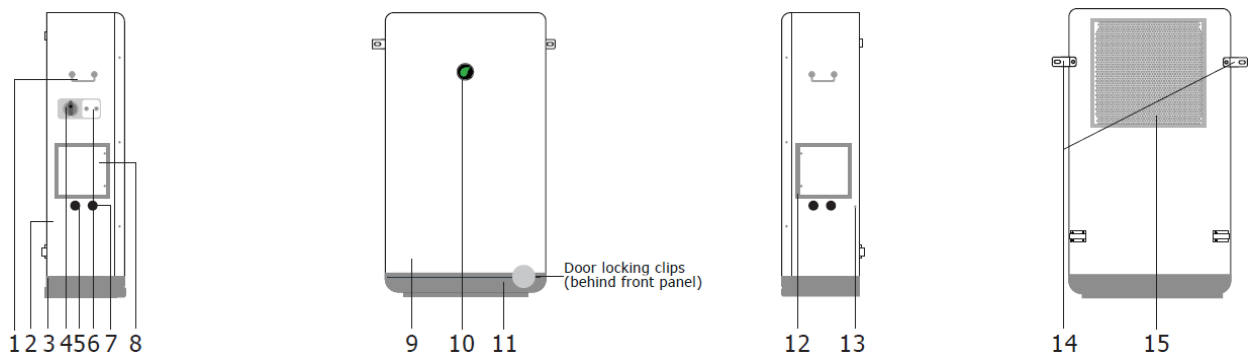

- 1 – Handle
- 2 – Battery enclosure
- 3 – Base
- 4 – Disconnect switch
- 5 – DC knockout
- 6 – Power button
- 7 – Communications knockout
- 8 – Inverter connection wirebox

- 9 – Front cover
- 10 – LED status indicator
- 11 – Base front cover

- 12 – Battery expansion wirebox
- 13 – GEC/bonding terminal
- 14 – Mounting tabs
- 15 – Heat sink

## Place and Prepare

To place and prepare a battery:

1. Choose a location with:
  - A level floor.
  - A plumb wall.
  - Minimum 914 mm (3 ft.) clearance side-to-side and top.
  - No direct sun or precipitation.

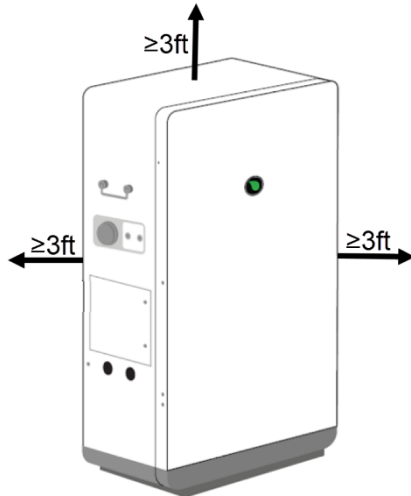

2. If mounting against a wall, affix the two side tabs.
3. Remove the front panel screws and two locking clips behind the base cover and open the enclosure.

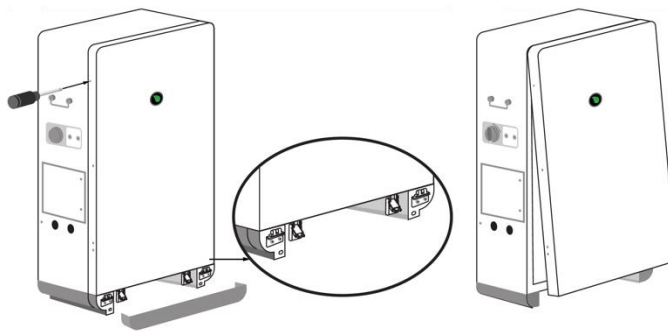

4. Detach the display and ground cables.

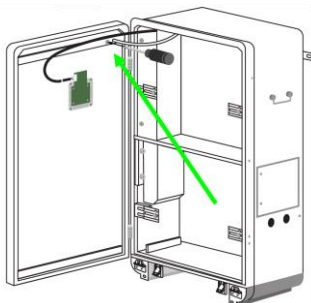

5. Place one battery module in the upper section and two modules in the lower section with the power terminals on the right side.
6. Secure the modules with the brackets attached to the enclosure.
7. In the upper section, connect the cables labeled *PCS*, *Upper bat Link-Out*, *Upper bat+* (red), and *Upper BAT-* (black) to their respective terminals.

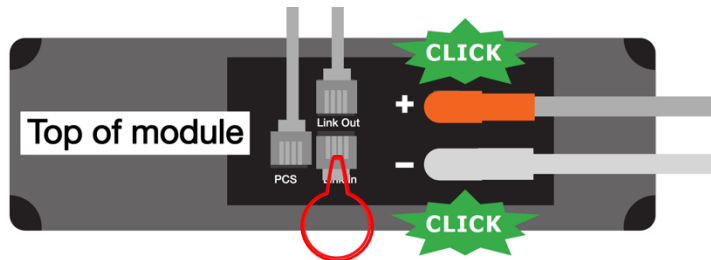

8. Insert an RJ45 terminator in the *Link In* terminal.  
The accessory bag in the battery module package includes two terminators.
9. In the lower section, connect the loose *Lower inner bat Link-Out* cable to the inner (back) module *Link Out* terminal and the outer (front) module *Link In* terminal.

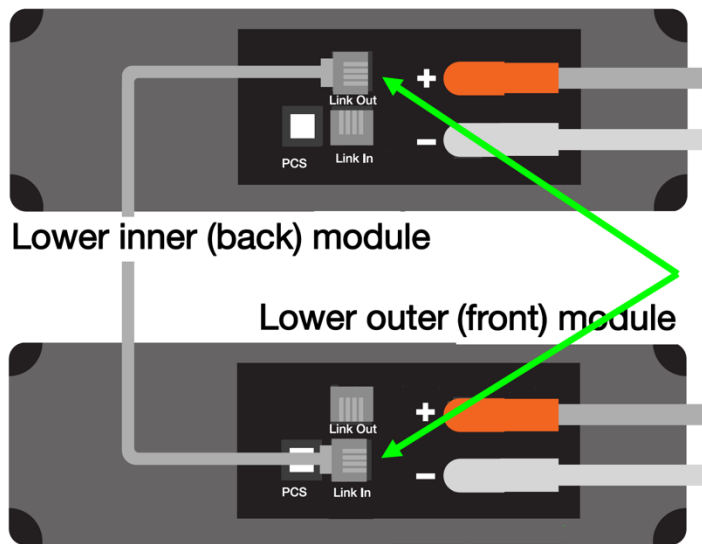

10. Connect the other cables according to their labels.



**CAUTION!**

**Remember to insert both Terminating Plugs on top Battery Module and side of Cabinet Can Com Port**



**CAUTION!**

**If commissioning on Battery Cabinet is not complete before leaving site:**

- Disconnect Battery Cabinet Communication cable to the Inverter
- Turn DC Switch Off on Battery Cabinet
- All terminating plugs must be installed in their respective ports

11. Insert an RJ45 terminator in the *CAN/COM* port located in the battery expansion wirebox on the enclosure right side.

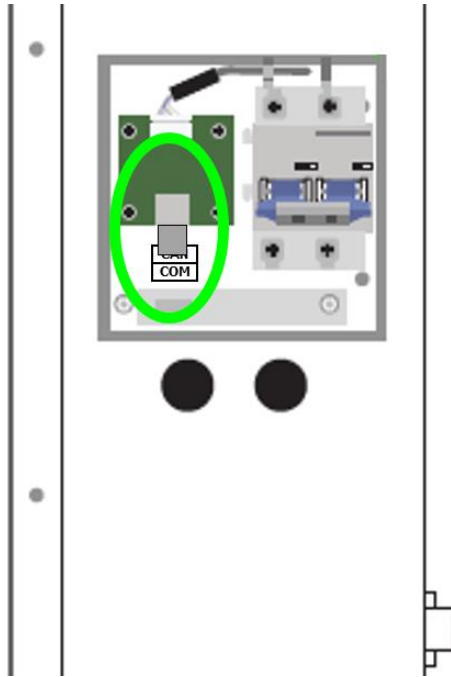

## Connect to the Inverter

To connect battery power conductors to the inverter:

1. In the inverter connection wirebox on the enclosure left side, connect two  $\leq 2\text{m}/6'7\text{in}$  conductors to the *BAT+* and *BAT-* terminals.

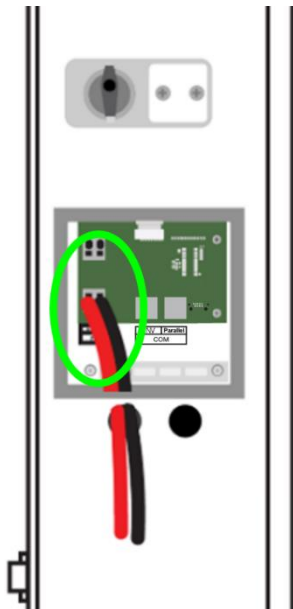

2. Connect the conductors to the inverter *BAT+* and *BAT-* terminals.

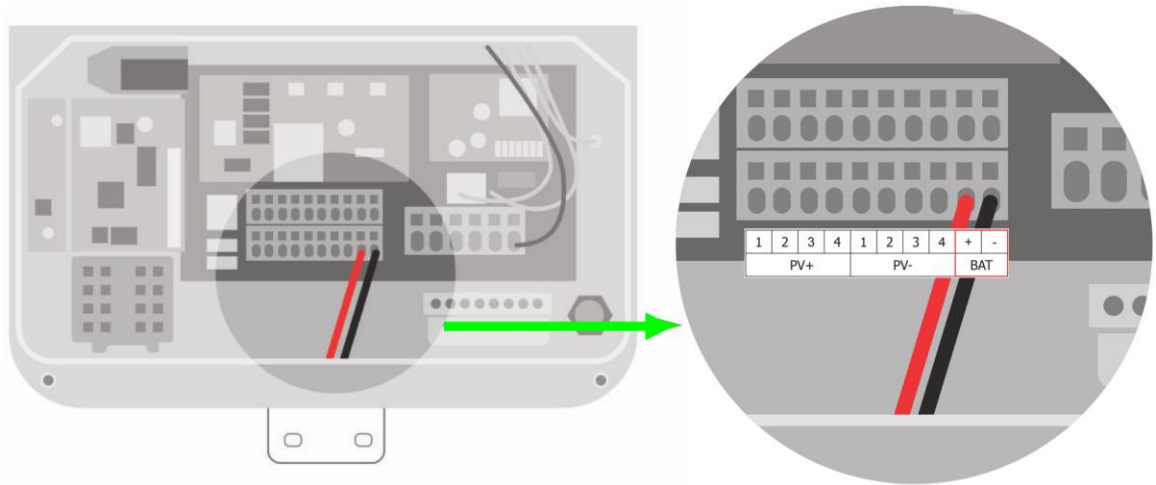

To connect the battery COM cable to the inverter:

1. In the battery inverter connection wirebox, plug the COM cable into the *COM INV* port.

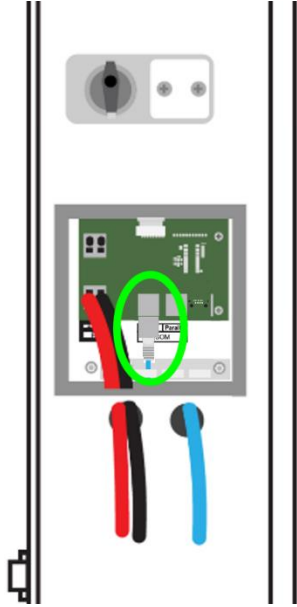

2. Plug the cable into the inverter battery *COM* port.

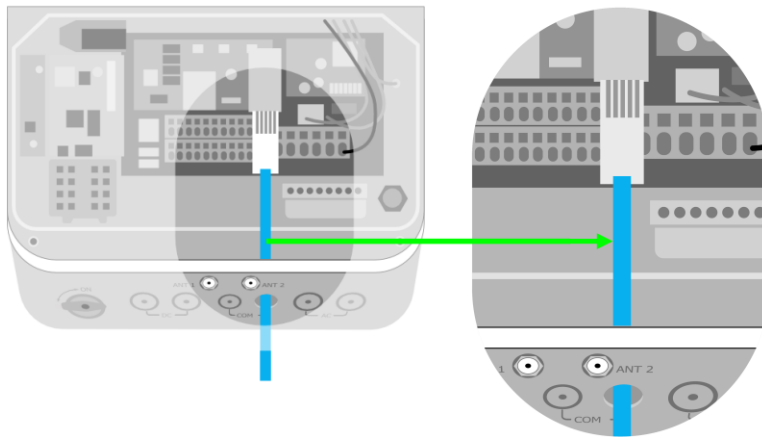

## Add Batteries

You may add:

- One, two or four batteries using a parallel connection.
- One battery using a serial connection (legacy installations only).



### CAUTION!

**It is not permissible to use three batteries in any configuration. Battery damage may occur.**

To add one battery in parallel:

1. In the battery expansion wireboxes, connect an RJ45 (CAT5/6 T586B) cable from the battery #1 *COM Parallel* plug to the battery #2 *COM Parallel* plug.

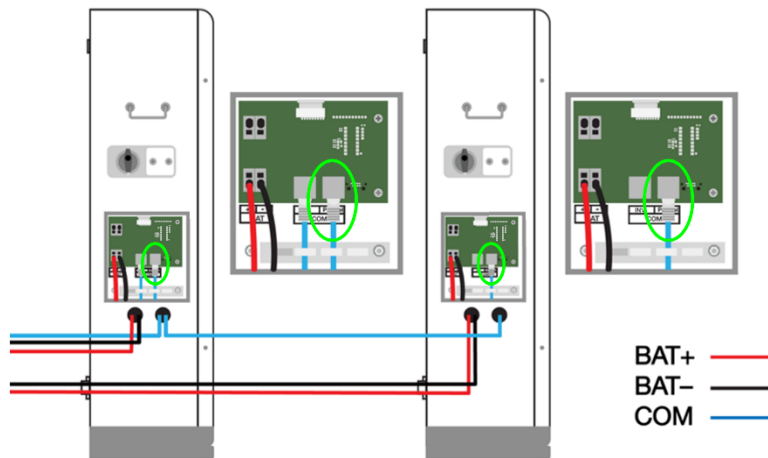

- Connect two  $\leq 2.5$  m (92 in.) conductors between the battery #2 BAT+ and BAT- terminals and the inverter BAT terminals.

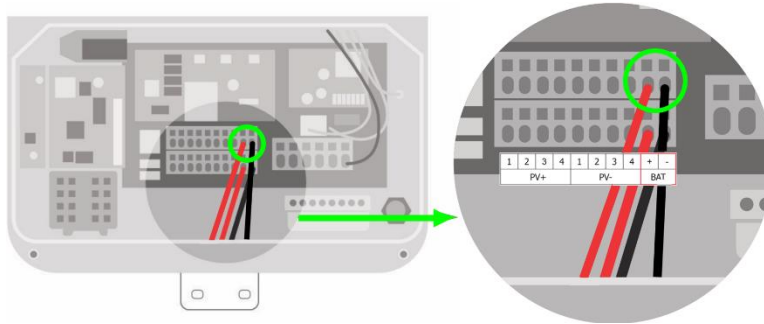

- In the battery expansion wireboxes, connect a terminator to each CAN/COM terminal.

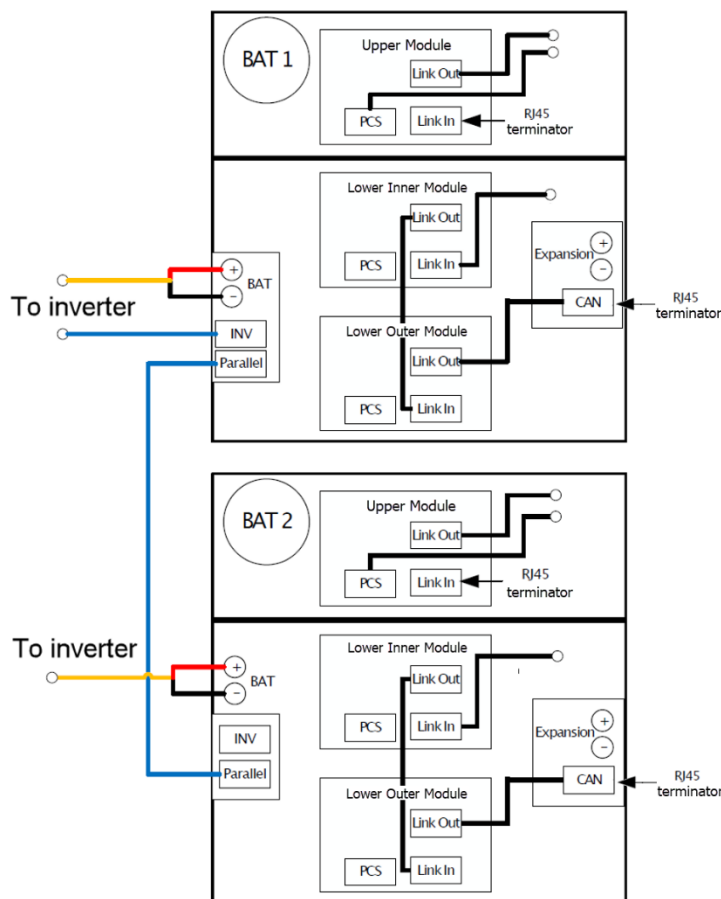

To add four batteries in parallel:

1. In the inverter connection wireboxes, connect a COM cable between the battery #1 and battery #2 *COM Parallel* RJ-45 ports.
2. Inside the battery enclosures, connect a COM cable from the battery #1 lower outer module *COM Link Out* plug to the battery #3 upper module *COM Link In* plug.
3. Inside the battery enclosures, connect a COM cable from the battery #2 lower outer module *COM Link Out* plug to the battery #4 upper module *COM Link In* plug.
4. In the battery expansion wireboxes, connect power conductors between the *BAT+* and *BAT-* terminals on batteries #1 and #3.
5. In the battery expansion wireboxes, connect power conductors between the *BAT+* and *BAT-* terminals on batteries #2 and #4.
6. In the battery expansion wireboxes, connect terminators to CAN/COM terminals on batteries #3 and #4.

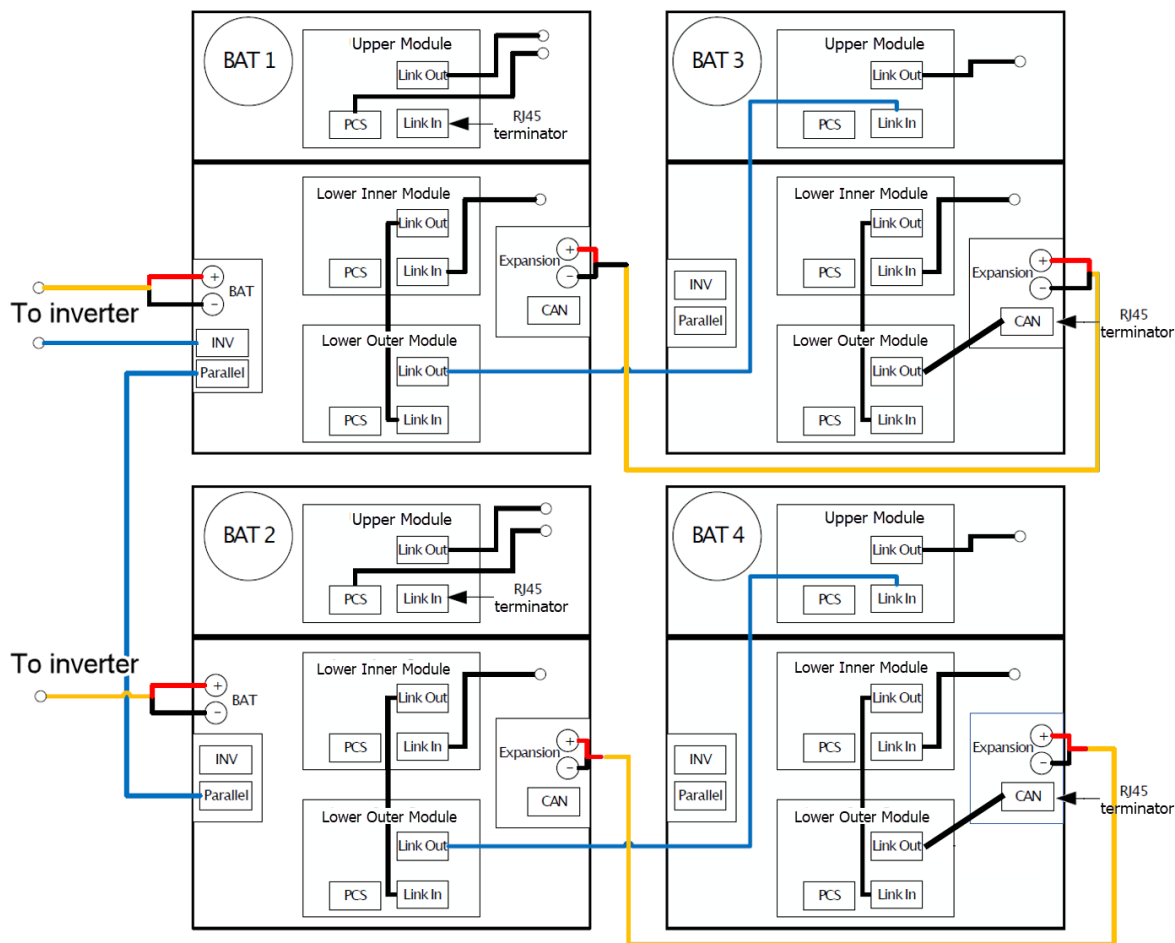

To add one battery with a serial connection (EI Battery part number 603-00000-10 only):

1. Inside the battery enclosures, connect a COM cable from the battery #1 lower outer module *COM Link Out* plug to the battery #2 upper module *COM Link In* plug.
2. In the battery expansion wireboxes, connect conductors between the *BAT+* and *BAT-* terminals on batteries #1 and #2.

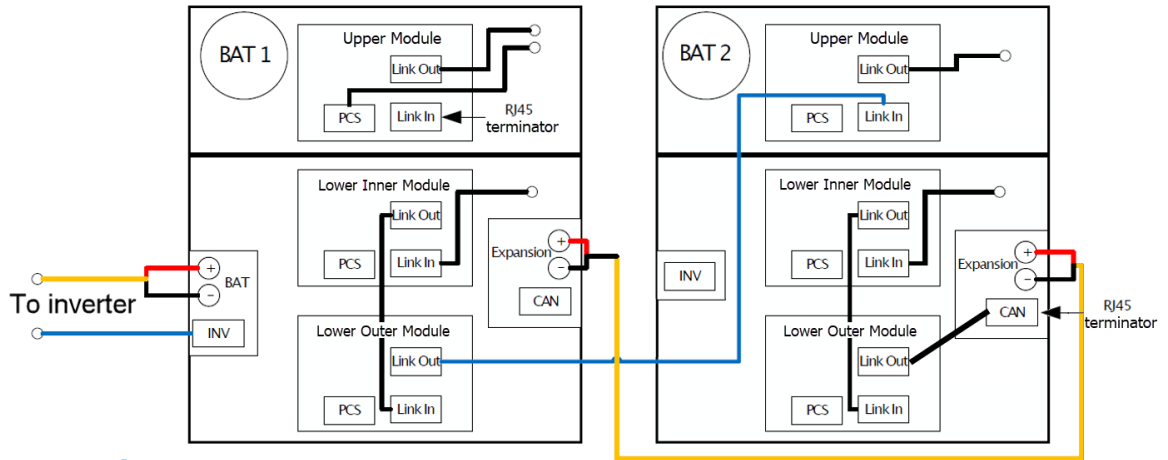

3. Insert a terminator in the battery #2 battery expansion wirebox CAN/COM terminal.

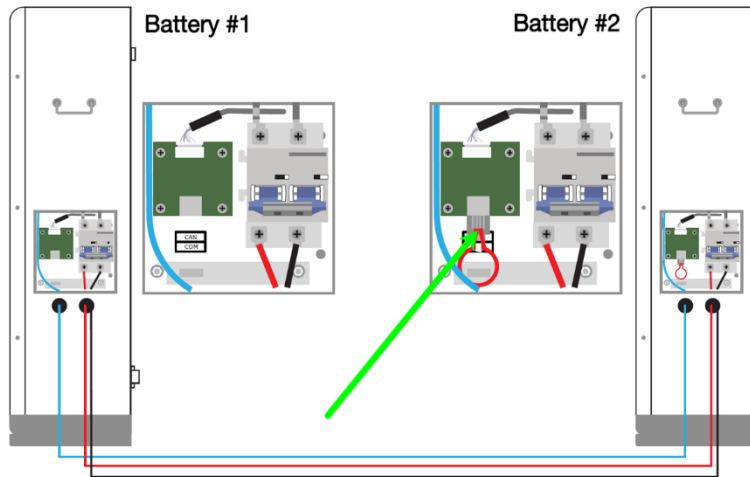

## Status Indicators

The green leaf and encircling four bars indicate the battery operating condition.

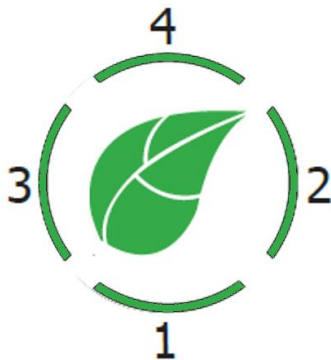

The leaf indicates battery status:

Status	Leaf
Standby	Flashing green (0.5 sec. on/2 sec. off)
Charging	Continuous green
Discharging	Continuous green
Alarm	Flashing green (0.5 sec. on/0.5 sec. off, 0.5 sec. on/2 sec. off)
Fault	Flashing red (1 sec. on/1 sec. off)
Upgrade	Flashing yellow (1 sec. on/1 sec. off)
Forced power on	Flashing green (0.1 sec. on/0.1 sec. off)
Forced shutdown	Flashing red (0.1 sec. on/0.1 sec. off)

LEDs indicate battery charge:

Charging	Discharging
≤25% – 1 flashes; 2, 3, 4 off	≤25% – 1 on; 2, 3, 4 off
≤50% – 1 on, 2 flashes; 3, 4 off	≤50% – 1, 2 on; 3, 4 off
≤75% – 1, 2 on, 3 flashes; 4 off	≤75% – 1, 2, 3 on; 4 off
≥75% – 1, 2, 3 on; 4 flashes	≥75% – 1, 2, 3, 4 on

## Forced Start/Shutdown

To force-start or shut down the battery:

1. On the left side of the battery enclosure, remove the power button cover.

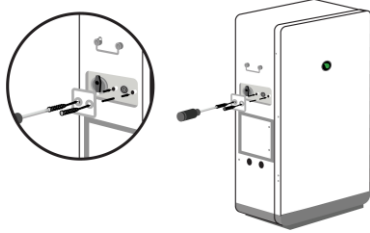

2. To force-start the battery, press the power button for 10 sec.  
The leaf status indicator starts flashing green (0.1 sec. on/0.1 sec. off).
3. To force a shutdown, press the power button for 10 sec.  
The leaf status indicator starts flashing red (0.1 sec. on/0.1 sec. off).
4. Reinstall the cover.

### **CAUTION!**

**If commissioning on Battery Cabinet is not complete before leaving site:**



- Disconnect Battery Cabinet Communication cable to the Inverter and Battery
- Turn DC Switch Off on Battery Cabinet
- All terminating plugs must be installed in their respective ports

### **CAUTION!**



**Failure to apply these steps can result in a deeply discharged battery that is unrecoverable and must be returned to Tigo.**

## TAP and TS4 MLPE

### Install the Tigo Access Point (TAP)

Installations equipped with TS4-A-O/S MLPE require a wired TAP connection to the inverter.

A TAP wirelessly communicates with TS4 devices to gather data and perform rapid shutdowns. The TAP connects to the link via a 4-wire or CAT5/6 cable.

Install the TAP centrally in an array for best coverage. Ensure there are no obstructions that may interfere with the TAP signal to other TS4 units in the array. If the array has multiple roof planes, you may need to install another TAP.

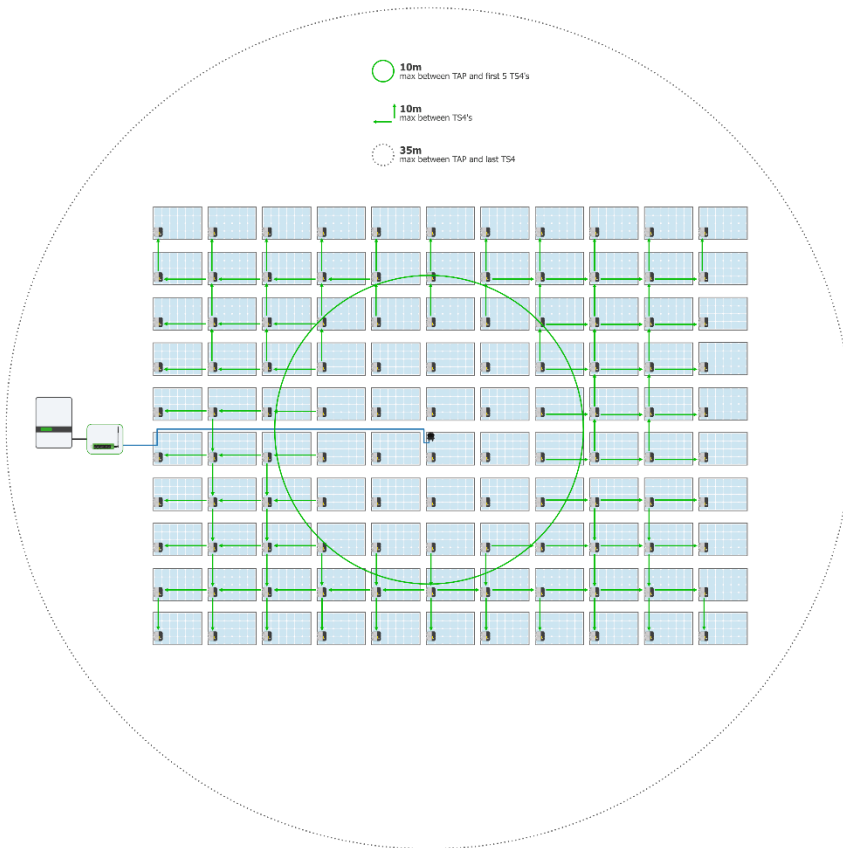

The TAP communicates directly with any TS4 within 10 m (33 ft.). Each TS4 can relay data to and from another TS4 within 10 m (33 ft.). The TAP can communicate through relays to any TS4s within 35 m (115 ft.).

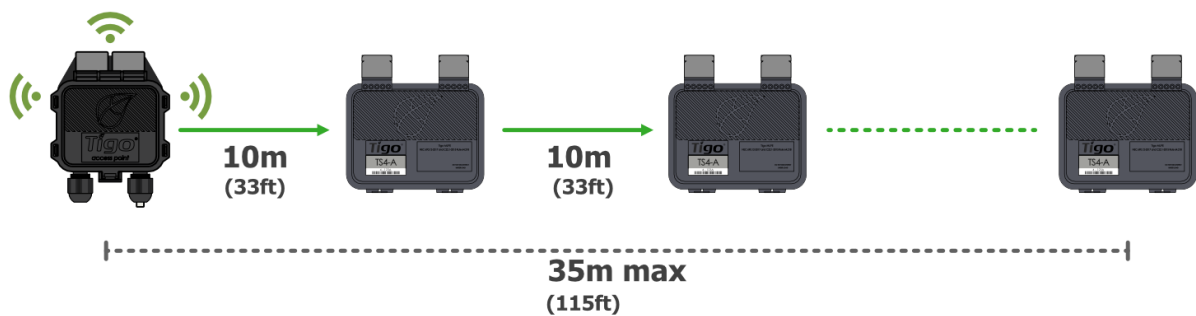

To install a TAP:

4. Prepare a 4-wire or CAT5/6 cable:
  - Shielded if running next to PV conductors
  - 20 – 18 AWG or CAT5/6 twisted pairs
  - Solid core
  - Cable outside diameter (OD)  $\leq$  9 mm (.35 in.)
5. Connect cable wires to the left side of the TAP using either the quick-connect (4-wire) or the terminal block (4-wire or CAT5/6 twisted pairs).

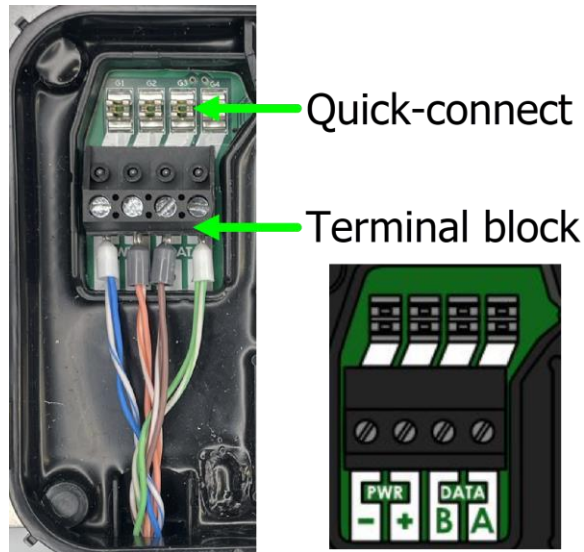

6. Use the right-side terminals to connect a cable to another TAP. If there is only one TAP, leave the terminating jumper in the right-side terminal block.
7. Attach the TAP to the PV module. For frameless modules, remove the silver clips and bolt directly to the rail.

8. Run the CAT5/6 cable through the inverter left COM knockout and connect to the 4-pin connector.

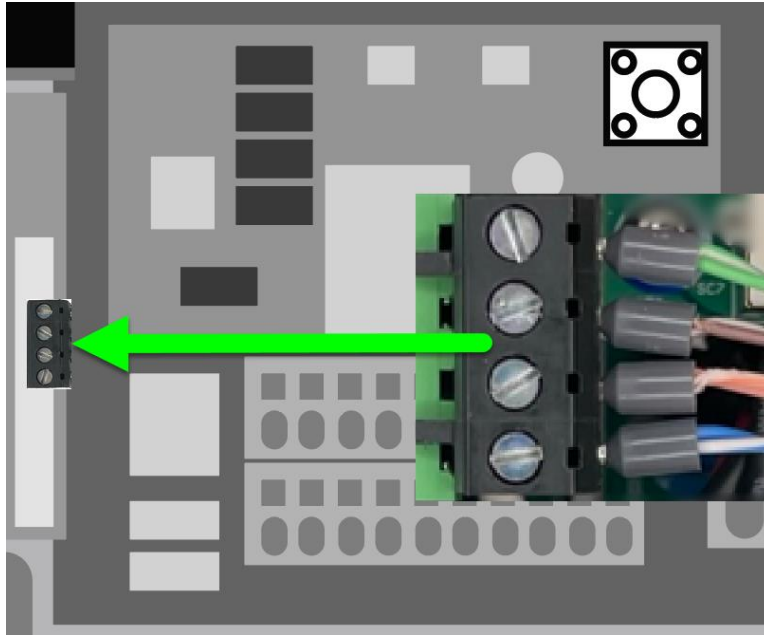

## Install TS4 MLPE

To install TS4 devices and map them for the Tigo Energy Intelligence app:

1. Attach a TS4 device to a PV module frame using the silver clips. If using frameless modules, remove the clips and bolt the TS4 directly to the PV rail with M8 bolts. No additional earthing is required.



If frame thickness  $\leq 35$  mm (1.4 in.), install the module with the TS4 label facing the PV module.



### CAUTION!

You must connect the shorter TS4 input leads to the PV modules first. Failure to do so can damage the TS4 unit.

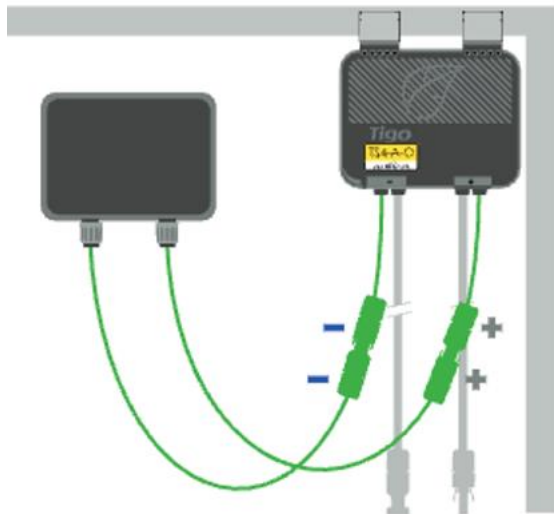

2. Remove the barcode sticker on the TS4 and place it on the PV array map located at the end of the EI Inverter Quick Start Guide. Ensure the sticker matches the physical location of the module on the roof.

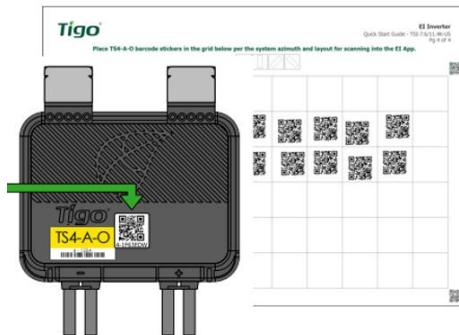

3. Connect the longer set of TS4 output cables to the neighboring TS4 to create a string.

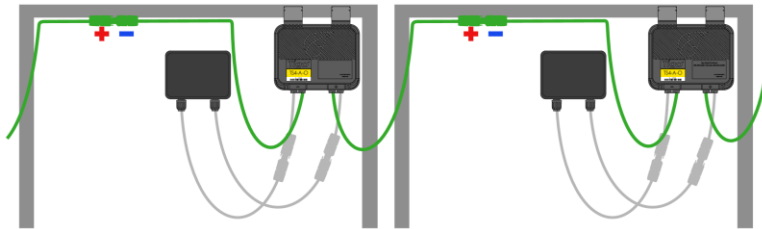

4. For installation data specific to your TS4 (TS4-A-O/S/M), visit the Tigo [Downloads](#) page:



## Commissioning

Commissioning must be performed by a licensed electrician or other qualified person in accordance with the latest local and NEC code requirements.

To commission the system, you will:

- Check Connections
- Power On the System
- Run the Tigo Energy Intelligence App

### Check Connections

Before powering on the system, ensure:

- PV and grid voltages are within specifications for your inverter model.
- A Wi-Fi connection is accessible.
- Power and communications connections are secure at the inverter, ATS, Rapid shutdown switch, battery, and service and load panels.
- Module racks, metal conduit, and enclosures are properly grounded.
- Unused enclosure knockouts are sealed.

### Power On the System

If the ATS is manually bypassed, restore automatic operations. Refer to the ATS [Manual Bypass Switch](#) section.

To power on the system:

1. Turn the two ATS breakers and the inverter and battery DC disconnects to ON.
2. Turn on disconnects/breakers between the grid and the ATS.
3. Ensure the Rapid shutdown switch shutdown button is not engaged.
4. If the inverter does not start, force-start the battery by removing the start button cover and pressing until the green leaf status LED flashes rapidly.
5. Ensure Bluetooth is enabled on your mobile device, open the Tigo EI app, and tap + to create a new system.
6. Open *Select Equipment*, tap *Scan*, and select the EI inverter.

If the inverter does not turn on, press, and hold the battery power button for 10s. If the inverter status LEDs continue to flash red and it does not start, contact Tigo support.



#### **CAUTION!**

- **Bypass Jumper is extremely important during Commissioning**
- **The ATS 50 Amp bypass jumper is required upon first startup of the ATS**
- **Please follow the instructions for Manually Bypassing the ATS**

## Run the Tigo Energy Intelligence App

The Tigo EI app for Android and iOS mobile devices enables fast system commissioning and provides comprehensive visibility into system and module performance.

Scan one of these QR codes to download the app.



To run the Tigo EI app and commission the system, first ensure Bluetooth is enabled on your mobile device.

Do not try to select your system using your mobile device's Bluetooth settings. The EI app will automatically connect to your system.

The EI app organizes the commissioning process into five steps:

- Set System Info
- Select Equipment
- Configure Layout
- Configure Communication
- System Access

The commissioning process will vary depending on your installation, and the following instructions may not completely address your needs. Visit the [tigoenergy.com](http://tigoenergy.com) [Help Center for more extensive instructions](#).

### Set System Info

1. Open the app and log in (existing users) or enroll.  
If you enroll in a new account, respond to the email message sent to verify your email address.



2. Tap + to configure a new system.

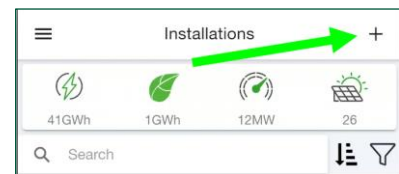

3. Enter the system name, turn on date, and tap *Next*.

4. Confirm your location and tap *Create* → to save the system information.

### Select Equipment

1. Tap *Select Equipment*.
2. Tap *Scan* to let the app scan for EI components such as the inverter and battery.

Tap *Add* to configure components manually.

The first component discovered is the EI Inverter or, in some cases, the Cloud Connect Advanced (CCA) component.

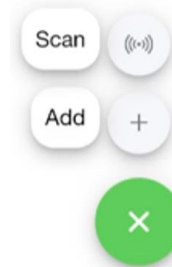
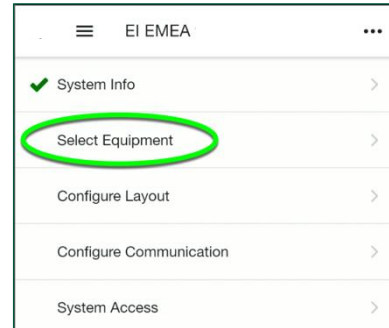

3. After a component is discovered or entered manually, tap *Add*.

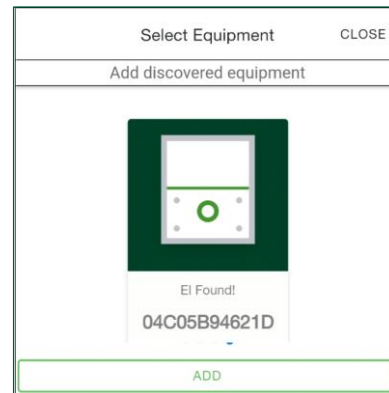

4. Tap *Internet Settings* and connect to the customer’s Wi-Fi network.

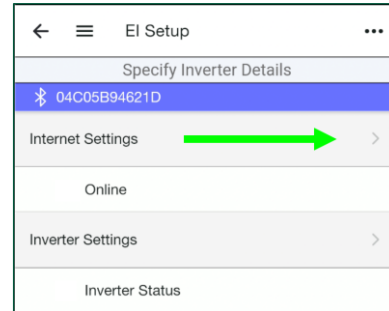

5. Drag the screen down to refresh the list of networks.

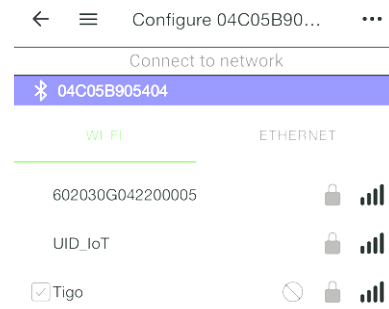

6. Perform updates as needed. As you progress through the commissioning process, symbols will show which areas need attention and which are complete:

- Section is complete and passes all checks.
- Section has not been completed.
- A fault requires correction.

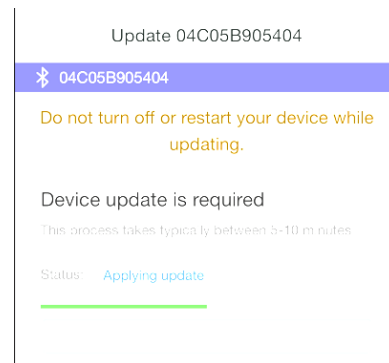

7. Tap *Inverter Settings*, select the *Grid Code*, configure *Advanced Options*, and tap *Save*.

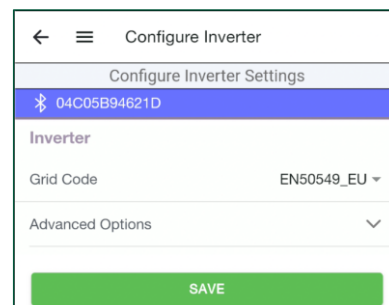

8. Configure *AC Meter*, *Battery Settings*, and *Main Breaker Limit* options as needed.

9. Tap and configure *Batteries & Meters* options.

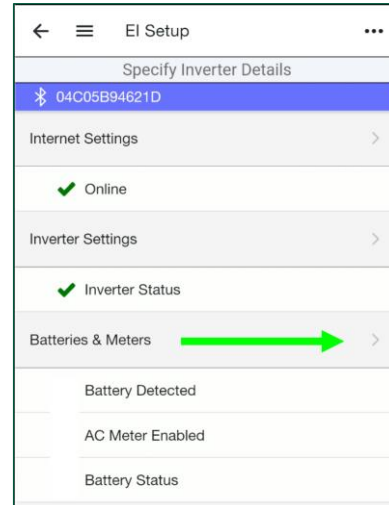

10. Tap *SCAN BARCODE FOR WARRANTY* and use your smartphone camera to capture all equipment bar codes.

You may scan bar codes located on enclosures or on boxes.

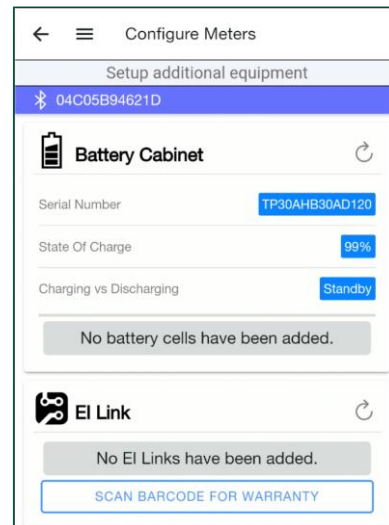

11. Tap the back arrow and tap *PV Modules* to set up the PV array and Tigo TS4 devices.

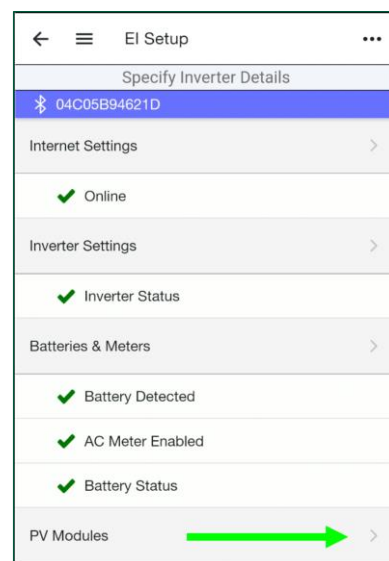

12. Edit inverter settings and tap **ADD STRING**.

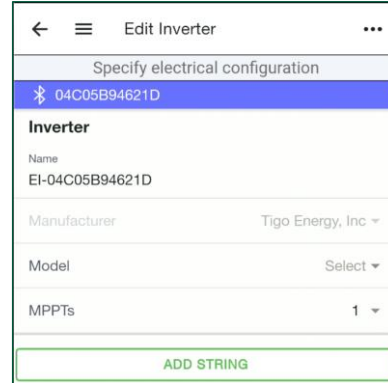

13. Select a *Manufacturer*, *Model*, and *PV Modules count* and tap **Save**.

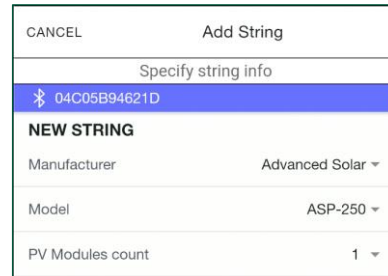

14. Repeat these steps for as many strings as needed and tap **Done**.

15. Review your entries and tap the back arrow.

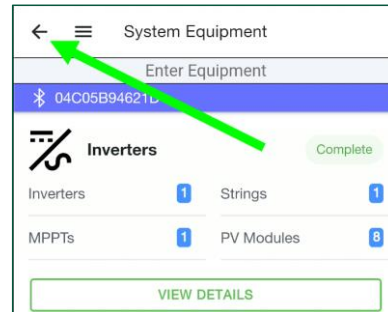

16. Check your system information at any time by tapping the three-dot icon and selecting *Real-Time Data*.

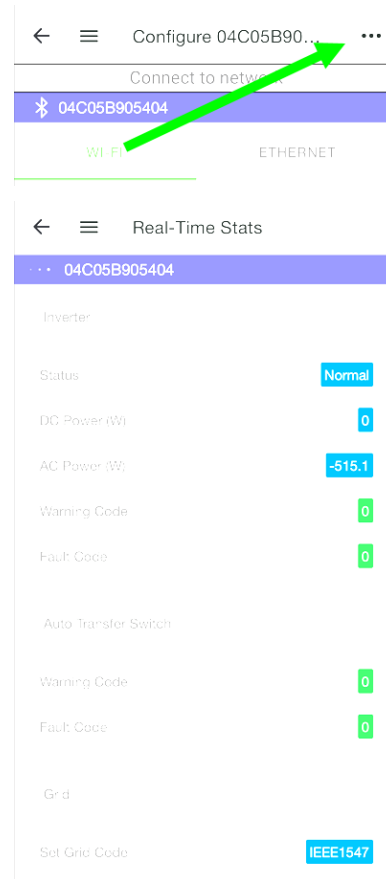

### Configure Layout

1. Tap *Configure Layout* to map equipment items on a layout grid.

You may also configure layout using a large monitor via the EI portal. Click Tigo EI Login at [www.tigoenergy.com](http://www.tigoenergy.com) and use your EI app credentials. However, you can only complete commissioning using the mobile app.

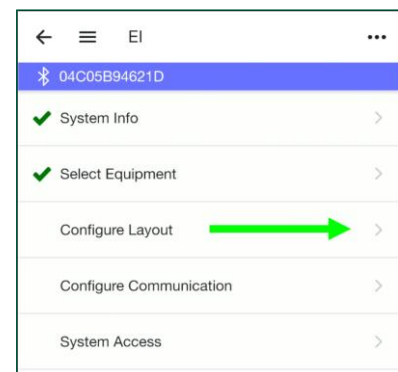

2. Tap the inverter icon at the bottom of the screen and then tap the location in the layout grid to place it.
  - The numbers below the equipment icons show the number of devices placed on the grid over the number detected.
  - Once placed, you may drag a device to adjust its location as needed.

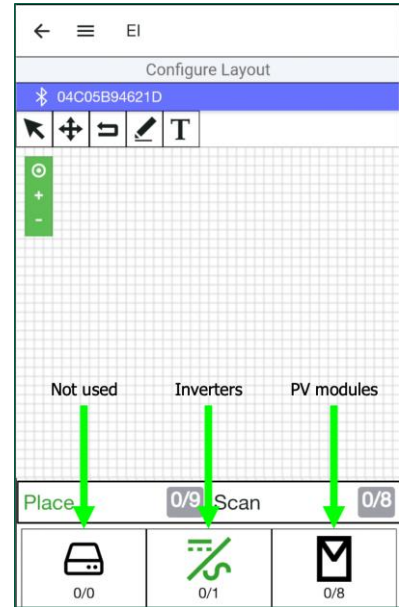

3. Drag the PV module icon to the layout grid to place multiple modules. Otherwise, tap the icon and then tap the grid to place them individually.
  - Arrange the modules carefully to reflect their actual layout on a roof or field. Tap a module to change its portrait/landscape orientation.

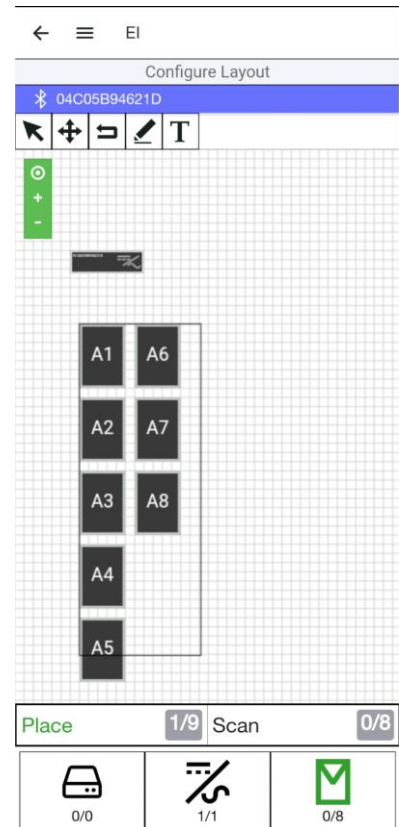

4. Choose a method to identify TS4 devices attached to PV modules.
  - If, during installation, you affixed barcode/QR code stickers from each TS4 to the array map included in the EI Inverter Quick Start Guide, you may use the Bulk Scan method.
  - You may scan each TS4 barcode/QR code with your smartphone.
  - You may enter codes manually.
5. To use the Bulk Scan method, tap *Bulk Scan* and take a photo of a completed TS4 array map.
  - If the array map is large and one photo does not successfully capture all labels, repeat the process to take several smaller photos of the map.

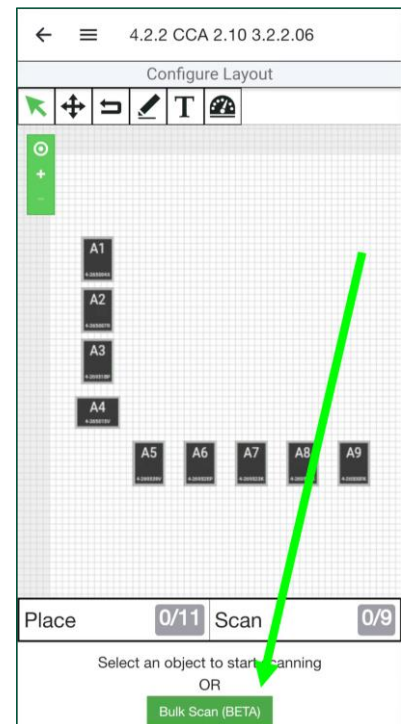

- To scan TS4 labels individually, tap a PV module in the layout grid and then tap *Scan*.

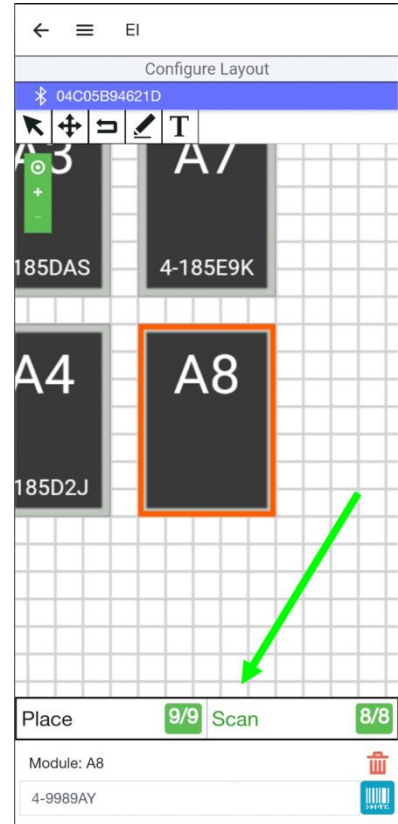

- To manually enter TS4 data, tap the module in the layout grid, tap the blue barcode icon, and enter the code.

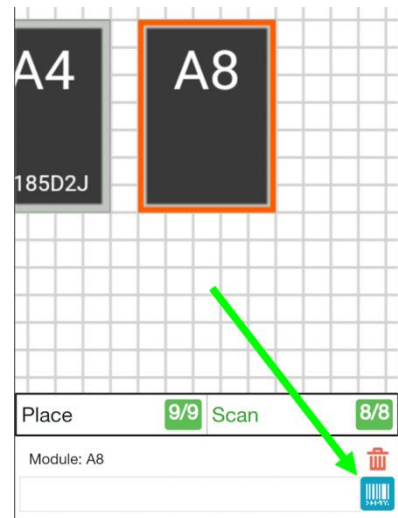

- Verify that all modules are oriented consistently – portrait or landscape. Tap a module repeatedly to alternate orientation.
- Tap the back arrow to return to the commissioning screen.

### Configure Communication

1. Tap *Configure Communication*.  
Bluetooth communication has already been established and the Wi-Fi option is not yet implemented.
2. Tap the back arrow to return to the commissioning screen.

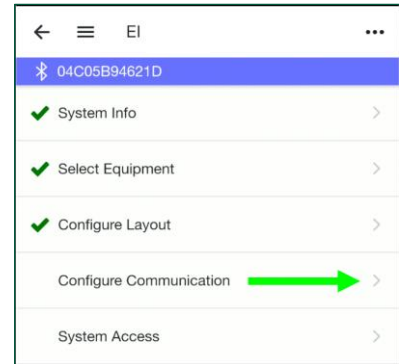

### Set Up System Access

1. Tap *System Access* to set access permissions.
2. Tap the Add icon to enter data for whoever will be accessing the system such as the installer and system owner.

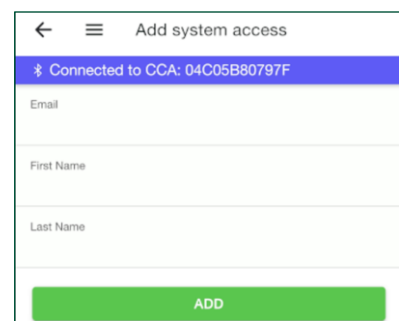
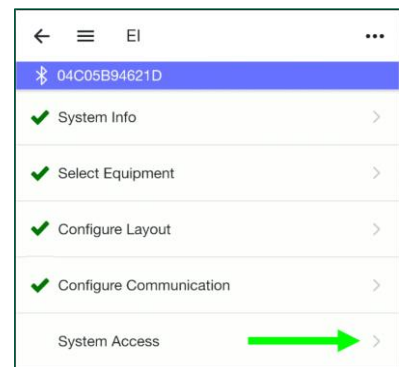

## Reference

This section includes the following topics:

- Error Codes
- Decommissioning
- Maintenance
- Customer Support
- Specifications
- Warranty

### Error Codes

To view error codes, open the EI app and navigate to the *Select Equipment > Inverters > View Details > Configure Inverter Details* screen and tap *Connect*.



**CAUTION!**

Shut down the system before checking PV module or system wiring.

If you are unable to resolve an error, visit the Tigo [Help Center](#).

#### *Inverter Warning Codes*

Code #	Description	Suggestions
203	PV1 or PV2 circuit short	1. Check PV panel polarity. 2. Restart the inverter.
204	Disconnect function abnormal	1. Shut down the system. 2. Check disconnect wiring.
205	PV1 or PV2 boost broken	Restart the inverter.
207	USB over-current	1. Unplug the USB disk or monitor. 2. Re-access USB disk or monitor after shutdown.
401	Inverter to energy meter abnormal communication	1. Check if the meter is on. 2. Check the inverter and the meter connection is normal.
404	EEPROM abnormal	Restart the inverter.
405	The firmware version is not consistent	Update inverter to the latest firmware version.

### *Inverter Fault Codes*

<b>Code #</b>	<b>Description</b>	<b>Suggestions</b>
402	Output high DCI	Restart the inverter.
404	Bus sample fault	Restart the inverter.
405	Relay fault	Restart the inverter.
408	Over temperature	Restart the inverter when the ambient temperature of the inverter is lower than 60 °C.
409	String voltage has exceeded 560 V <sub>DC</sub>	Restart the inverter.
411	DSP communicates M3 abnormal	<ol style="list-style-type: none"> <li>1. Restart the inverter.</li> <li>2. If the problem still exists, update the DSP and M3 firmware.</li> <li>3. Change the DSP or M3 board.</li> </ol>
417	The data sampled by the DSP and redundant M3 are not the same.	Restart the inverter.
420	GFCI fault	Restart the inverter.

### System Fault Codes

Code #	Error Message	Description	Suggestions
201	Residual I high	Leakage current too high	Restart the inverter.
202	PV voltage high	The DC input voltage is exceeding the maximum tolerable value.	<ol style="list-style-type: none"> <li>1. Disconnect the DC switch immediately.</li> <li>2. Check the voltage of each PV string with a multimeter.</li> </ol>
203	PV isolation low	Insulation problem	<ol style="list-style-type: none"> <li>1. Check if the panel enclosure is grounded properly.</li> <li>2. Check if the inverter is grounded properly.</li> <li>3. Check if the DC breaker is wet.</li> <li>4. Check the impedance of PV + and PV – between ground (&gt;25 K<math>\Omega</math> or 550 K<math>\Omega</math> (VDE 0126)).</li> </ol>
300	AC V out range	The utility grid voltage is out of permissible range.	<ol style="list-style-type: none"> <li>1. Switch off the DC disconnect.</li> <li>2. Check AC wiring especially the neutral and ground wires.</li> <li>3. Verify grid voltage is within tolerances.</li> <li>4. Restart the inverter.</li> </ol>
302	No AC connection	No AC connection The inverter does not detect grid voltage.	<ol style="list-style-type: none"> <li>1. Check AC wiring connections.</li> <li>2. Check the status of the AC breaker.</li> </ol>
303	PE abnormal	Neutral and PE voltages exceed 30 V.	<ol style="list-style-type: none"> <li>1. Check neutral and PE voltages.</li> <li>2. Check AC wiring.</li> <li>3. Restart the inverter.</li> </ol>
304	AC F out range	Utility grid frequency out of permissible range.	<ol style="list-style-type: none"> <li>1. Switch off the DC disconnect.</li> <li>2. Check AC wiring especially the neutral and ground wires.</li> <li>3. Verify grid frequency is within allowable tolerance (59.3 to 60.8 Hz).</li> <li>4. Restart the inverter.</li> </ol>
407	Auto test failed	The EI Inverter initial auto test has failed.	<ol style="list-style-type: none"> <li>1. Restart the inverter.</li> <li>2. Repeat auto test.</li> <li>3. Check all connections and wiring.</li> <li>4. Check DC, AC, and battery voltage readings and if Grid selection in the app matches the actual Grid reading.</li> <li>5. Check the firmware version and update if needed.</li> </ol>
500	BMS COM fault	BMS not able to communicate properly with the inverter.	<ol style="list-style-type: none"> <li>1. Check RS485 cable connection.</li> <li>2. Check if the battery is sleeping.</li> </ol>

## Decommissioning



### CAUTION!

Wait five minutes after complete system shutdown for enclosures to cool before disassembling the system.

To decommission the system:

1. Turn off the system by reversing the procedure listed in the [Power On the System](#) section.
2. Contact [support@tigoenergy.com](mailto:support@tigoenergy.com) to deactivate the system in the Tigo database.

Follow these precautions with the battery modules:

- Pack modules in the original packaging or equivalent carton.
- Store modules in a dry location with ambient temperatures of -30 °C to 50 °C and relative humidity of 0-100% for up to three months.
- Do not store near flammable or toxic substances.
- Recycle or dispose of battery modules in compliance with local regulations.

## Maintenance

A qualified service technician must evaluate any operational problems or external damage. In addition:

- Clean surfaces with a damp cloth only. Never use solvents or abrasives.
- Maintain proper clearances around all enclosures to ensure proper air circulation.
- Check enclosures quarterly and remove any insects and rodent nests.

## Specifications

Download comprehensive specifications for all Tigo products from the Tigoenergy.com [Downloads](#) ([www.tigoenergy.com/downloads](http://www.tigoenergy.com/downloads)) page.

## Warranty

Download comprehensive warranty information from the Tigoenergy.com [Downloads](#) ([www.tigoenergy.com/downloads](http://www.tigoenergy.com/downloads)) page.

## Customer Support

---

The Tigo support team is available by:

- Chatting with a tech through the Tigo EI app.
- Submitting a ticket from the Tigo EI app.
- Submitting a ticket through the [Tigo Help Center](#).
- Call +1 408 402 0802.

Support hours are Monday – Friday, 7am – 6pm PST.

In addition, the [Tigo Community web forum](#) is an important 24/7 resource where solar technicians learn, share, and collaborate.

When you contact Tigo support for installation or operational assistance:

- If the system is commissioned and connected to the internet, Tigo will have component-level data to help understand and resolve the issue.
- If you have not yet commissioned the system, you will need to know your System ID as well as serial and model numbers for the inverter, battery, and MLPE components relevant to your issue.

Support will need:

- A description and history of the problem.
- Any relevant error codes.
- A procedure for reproducing the problem, if possible.
- Grid and DC input voltage (for inverters).
- Ambient weather conditions.
- If module-level monitoring was not installed or was improperly mapped, you may be asked for the module manufacturer, model, wattage,  $V_{OC}$ ,  $V_{MP}$ ,  $I_{MP}$ , and the number of modules in each string.

## Appendix A – UL 1741 PCS CRD Section 208 Information

The major system elements making up the Tigo power control system (PCS) include:

- A hybrid inverter: TSI-3.8K-US, TSI-7.6K-US, or TSI-11.4K-US
- A smart energy meter built into the inverter
- An EI or GO Battery MSX

### Integrations

A DC-coupled integration is shown below:

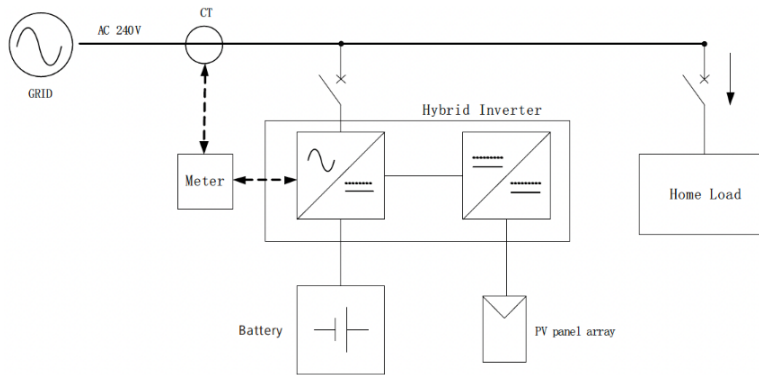

An AC-coupled integration is shown below:

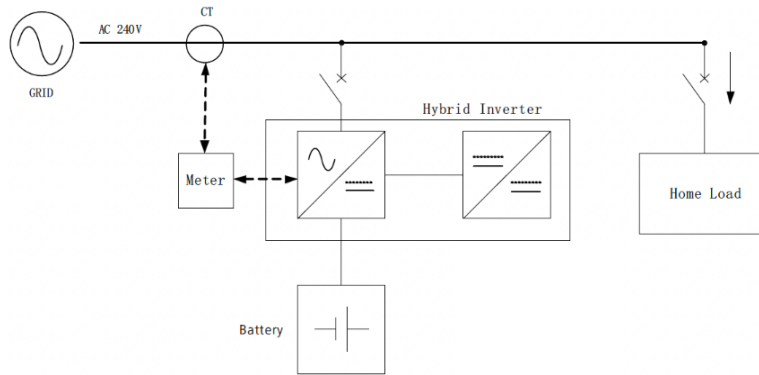

The Tigo PCS supports the following operational modes:

- Time of Use
- Self-Consumption
- Backup
- Zero Export

To set a mode and adjust settings:

1. Open the Tigo Energy Intelligence mobile app.



2. Tap the Settings icon.

## Time of Use

This mode controls when the grid may be used to charge the battery.

To configure *Time of Use* settings:

1. Select *Energy/Battery Management > System Behavior > Time of Use*.

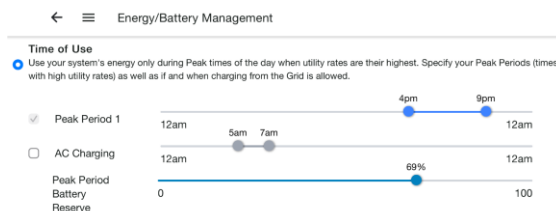

2. Adjust the sliders to set when utility rates are highest, when the battery can be charged from the grid, and a desired battery reserve during peak periods (how much energy to save in case of grid failure).

## Self-Consumption

This mode controls the battery reserve to enable minimizing grid usage.

To configure *Self-Consumption* settings:

1. Select *Energy/Battery Management > System Behavior > Self-Consumption*.

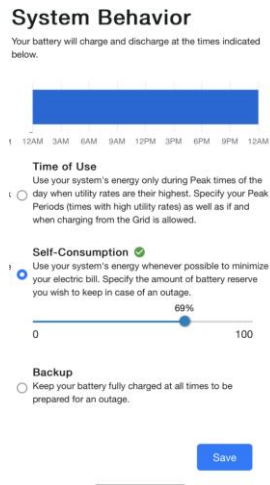

2. Adjust the slider to set a desired battery reserve (how much energy to save in case of grid failure).

## Backup

This mode controls the battery reserve to enable maximizing backup energy in case of an outage.

To configure *Backup* settings:

1. Select *Energy/Battery Management > System Behavior > Backup*.

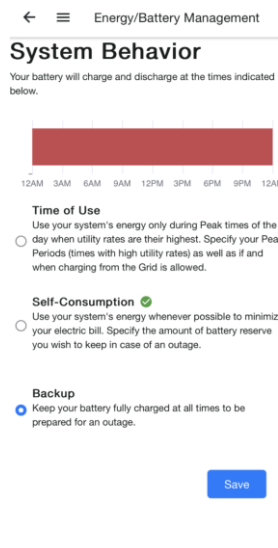

2. Tap the *Backup* control.

## Zero Export

This inverter setting enables or disables sending energy to the grid.

To configure *Zero Export* settings:

1. Select *Edit System > Select Equipment > Inverter > View Details > Connect > Inverter Settings > Grid Code > Advanced Options > AC Meter*.

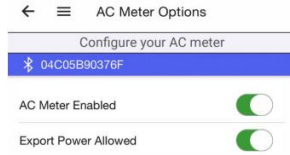

2. Toggle off the *Export Power Allowed* setting.

## Appendix B – Configuring HECO Requirements

The Hawaiian Electric Company's (HECO) tariff Rule No. 14 Section H concerns the interconnection of distributed generating facilities operating in parallel with the company's electric system.

To configure the inverter for HECO requirements, you must set voltage levels and disable sending energy to the grid with the *Zero Export* setting.

To set voltage levels:

1. Open the Tigo Energy Intelligence mobile app.
2. Select *Settings > Edit System > Select Equipment > Inverter > View Details > Connect > Inverter Settings > Grid Code > Advanced Options > HECO*.

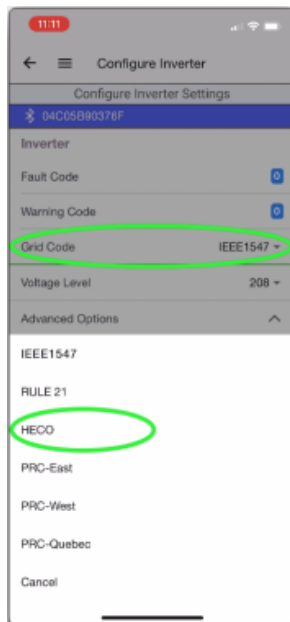

3. Select *Advanced Options > Voltage Level* and set appropriate levels.

To configure *Zero Export* settings:

1. Open the Tigo Energy Intelligence mobile app.
2. Select *Settings > Edit System > Select Equipment > Inverter > View Details > Connect > Inverter Settings > Grid Code > Advanced Options > AC Meter*.



3. Toggle off the *Export Power Allowed* setting.